



EPA Certified / Stationary Emergency

OUTPUT POWER OPTIONS					STANDBY RATING		sKVA
Make	Voltage	Alternator	Phase	Hertz	kW/kVA	Amps	30% Voltage Dip
Stamford	600	S0L1-P41-17	3	60	12/15	14	47
	277/480	S0L1-P41-311	3	60	12/15	18	19
	120/208	S0L1-P41-311	3	60	12/15	42	13
	120/240	S0L1-P41-311	3	60	12/15	36	13
	120/240	S0L1-P41-311	1	60	9/9	38	10
	120/240	S0L1-S41-706	1	60	12/12	50	19
Marathon	600	282PSL5247	3	60	12/15	14	48
	277/480	282CSL1504	3	60	12/15	18	48
	120/208	282CSL1504	3	60	12/15	42	36
	120/240	282CSL1504	3	60	12/15	36	36
	120/240	282CSL1504	1	60	12/12	50	18
	120/240	282CSL1515	1	60	12/12	50	26



Engine Data

Manufacturer	Perkins
Model	403F-15
Aspiration	Naturally Aspirated
EPA Tier	4 Final
Charge Air Cooling System	Air-to-Air
Arrangement	Vertical Inline, 4-Cycle
Firing Order	1-2-3
Displacement: L (in. ³)	1.496 (91.29)
Bore: mm (in.)	84.00 (3.31)
Stroke: mm (in.)	90.00 (3.54)
Compression Ratio	22.5:1
BMEP: psi (kPa)	90.50 (624.00)
Net Horsepower	18.36
Rated RPM	1800
Governor	Mechanical
Speed Regulation	±0.75%

Engine Liquid Capacity

Oil System: qt. (L)	6.34 (6.00)
---------------------	-------------

Engine Electrical

Electric Volts: DC	12
Cold Cranking Amps	450
Battery(s) Required	1

Fuel System

Fuel Injection Type	Indirect
Fuel Pump Rate: gal/hr (L/hr)	0.28 (1.05)
Pump Pressure: in. H ₂ O (kPa)	50.00 (10.00)
Max Suction Head: ft (m)	2.63 (0.80)
Max Pressure Head: ft (m)	9.84 (3.00)
Recommended Fuel	Ultra Low Sulfur Diesel

Air Requirements

Air Filter(s) Type	Dry
Combustion Air Flow: CFM (m ³ /min)	48.38 (1.37)
Maximum Air Intake Restriction	
Clean: in. H ₂ O (kPa)	12.04 (3.00)
Dirty: in. H ₂ O (kPa)	25.69 (6.40)
Radiator Air Flow: CFM (m ³ /min)	1080.6 (30.6)

Exhaust System

Gas Temperature: °F (°C)	824.0 (440.0)
Gas Flow: CFM (m ³ /min)	98.88 (2.80)
Max Back Pressure: in. H ₂ O (kPa)	40.94 (10.20)
Exhaust Outlet Size: in. (mm)	1.65 (42.00)

Sound Level

Open Unit Without Exhaust: dBA 3.2 ft (1M)	N/A
--	-----

Filters and Quantity

Air Cleaner Quantity	1
Oil Filter(s) Quantity	1
Fuel Filter(s) Quantity	1

Fuel Consumption

At 100% of Power Rating: gal/hr (L/hr)	0.96 (3.64)
At 75% of Power Rating: gal/hr (L/hr)	0.73 (2.76)
At 50% of Power Rating: gal/hr (L/hr)	0.51 (1.94)
At 25% of Power Rating: gal/hr (L/hr)	0.30 (1.13)

Cooling System

Rejection to Radiation: kW (BTUM)	4.00 (227.48)
Rejection to Fluids: kW (BTUM)	13.4 (762.1)
Coolant Flow: gal/min (L/min)	15.27 (57.80)

Alternator Data

Manufacturer	Stamford
Type	Self-Excited
Insulation Class	NEMA H
Temperature Rise	125°C Standby
Hertz	60
RPM	1800
Amortisseur Windings	Full
CFM Cooling Required	148
Voltage Regulator	AS540
Sensing	Single Phase
Voltage Regulation	1.0%

Features

- BS EN 60034, BS5000, VDE 0530, NEMA MG1-32, IEC34, CSA C22.2-100, and AS1359 compliant
- IP23 enclosure
- Dynamically balanced to exceed BS6861:Part 1 Grade 2.5 vibration standard
- Quality assurance to BS EN ISO 9001
- Self-ventilated and drip proof construction
- Two-thirds pitch stator and skewed rotor
- Heavy duty bearings
- Fully guarded
- Overexcitation protection
- Under frequency protection
- Overload protection
- Paralleling compatible
- Single-phase sensing

Alternator Data

Manufacturer	Marathon
Type	Self-Excited
Insulation Class	NEMA N
Temperature Rise	125°C Standby
Hertz	60
RPM	1800
Amortisseur Windings	Full
CFM Cooling Required	250
Voltage Regulator	SE350
Sensing	Single Phase
Voltage Regulation	1.0%

Features

- NEMA MG1-32, BS5000, and IEC 34-1 compliant; CE & CSA Certified and UL Listed
- Self-ventilated and drip proof construction
- Two-thirds pitch stator and skewed rotor
- Wet wound, epoxied field windings
- Designed to withstand overspeeds of up to 125%
- Analog voltage regulator
- Easy access front-panel adjustments
- Under-frequency, stability and voltage adjustments
- Internal provisions for automatic voltage build up from generator residual voltage
- Electromagnetic interference filter

Control Panels



DeepSea 7310 MKII

Simultaneous Use of RS232 & RS485
 Modbus RTU Support
 Fully Configurable Using USB, RS232 & RS485
 IP65 Rating
 6 Programmable Inputs & 8 Outputs
 UL & cUL Listed and CE Certified



Basler DGC2020

SAE J1939 Engine ECU Communications
 4 Programmable Inputs & 10 Outputs
 Modbus Communications With RS485
 UL Recognized, CSA & CE Certified
 IP 54 Front Panel Rating
 NFPA 110 Level 1 Compatible
 Manual Override Keyswitch
 DGC2020HD Variant Available



Taylor Analog

Automatic CANBUS Engine Control
 Gauge Zeroing on Shutdown
 Auto-Off-Manual Control Switch
 Oil Pressure, Water Temperature, Battery Voltage and RPM Gauges
 AC Voltage, Frequency, Percent of Load, and Run-Time Metering
 LED Status Lights

Standard Features:

Warranty

2 Year Standard
5 Year Comprehensive

- | | |
|------------------------------------|------------------------|
| Heavy Duty Steel Base | Battery Charger |
| Vibration Isolators | Block Heater |
| Oil Drain Valve with Extension | Factory Powder Coating |
| Coolant Drain Kit | Factory Load Test |
| High Ambient Unit Mounted Radiator | Owner's Manual |

Controller Options

DGC2020HD Controller
Fiber Optic Ethernet (DGC2020HD)
RS-232 Port & Generator Protection (DGC2020)
Flush or Surface Mount Remote Annunciator
Remote Mount Break Glass E-Stop Switch

Miscellaneous Options:

- | | |
|------------------------|-------------------------|
| Generator Strip Heater | Pad Type Battery Heater |
| Spring Isolators | Battery Heater Blanket |
| Line Circuit Breaker | Oil Pan Heater |

Open Unit

Options:

- Radiator Duct Flange
- Flex Exhaust
- Critical Silencer
- Sub-Base Fuel Tank

Overall Size: 60"L x 32"W x 51"H
Approximate Weight: 1,150 lbs.

Note: Dimensions and weights reflect standard open unit with no options and are subject to change.

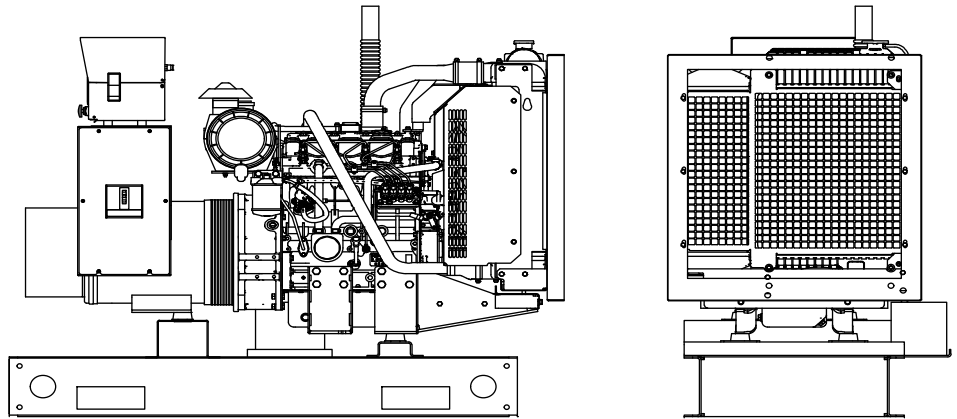

Standard Enclosed Unit

Options:

- Sound Attenuated Enclosure
- Load Center, Lights & GFI Receptacle
- Sub-Base Fuel Tank

Overall Size: 78"L x 46"W x 46"H
Approximate Weight: 1,400 lbs.

Note: Dimensions and weights reflect standard enclosed unit with no options and are subject to change.

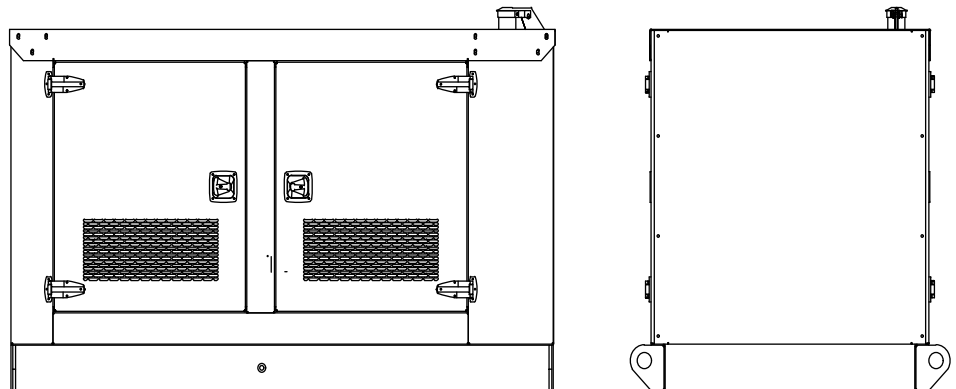

Note: The above drawings are provided for reference only and should not be used for planning installation. Contact your local distributor for more information.