



SIRIUS Compact load feeder DOL starter 690 V 110...240 V AC/DC 50...60 Hz
0.1...0.4 A IP20 Connection main circuit: screw terminal Connection auxiliary
circuit: screw terminal

product brand name	SIRIUS
product designation	compact starter
design of the product	direct starter
product type designation	3RA61
General technical data	
product function control circuit interface to parallel wiring	Yes
product extension auxiliary switch	Yes
power loss [W] for rated value of the current	
• at AC in hot operating state	0.01 W
• at AC in hot operating state per pole	0.01 W
• without load current share typical	6 W
insulation voltage rated value	690 V
degree of pollution	3
surge voltage resistance rated value	6 000 V
maximum permissible voltage for protective separation	
• between main and auxiliary circuit	400 V
• between auxiliary and auxiliary circuit	250 V
• between control and auxiliary circuit	300 V
degree of protection NEMA rating	other
shock resistance	a=60 m/s ² (6g) with 10 ms per 3 shocks in all axes
mechanical service life (operating cycles)	
• of the main contacts typical	10 000 000
• of auxiliary contacts typical	10 000 000
• of the signaling contacts typical	10 000 000
electrical endurance (operating cycles) of auxiliary contacts	
• at DC-13 at 6 A at 24 V typical	30 000
• at AC-15 at 6 A at 230 V typical	200 000
type of assignment	continuous operation according to IEC 60947-6-2
reference code according to IEC 81346-2	Q
Substance Prohibitance (Date)	05/01/2012
SVHC substance name	Lead - 7439-92-1 Lead monoxide (lead oxide) - 1317-36-8 Lead titanium zirconium oxide - 12626-81-2
Ambient conditions	
installation altitude at height above sea level maximum	2 000 m
ambient temperature	
• during operation	-20 ... +60 °C
• during storage	-55 ... +80 °C
• during transport	-55 ... +80 °C
relative humidity during operation	10 ... 90 %
Main circuit	

number of poles for main current circuit	3
adjustable current response value current of the current-dependent overload release	0.1 ... 0.4 A
formula for making capacity limit current	120 x I _e
formula for limit current breaking capacity	100 x I _e
yielded mechanical performance for 4-pole AC motor	
• at 400 V rated value	0.09 kW
• at 500 V rated value	0.12 kW
• at 690 V rated value	0.18 kW
operating voltage at AC-3 rated value maximum	690 V
operational current	
• at AC at 400 V rated value	0.4 A
• at AC-3 at 400 V rated value	0.4 A
• at AC-43	
— at 400 V rated value	0.3 A
— at 500 V rated value	0.32 A
— at 690 V rated value	0.35 A
operating power	
• at AC-3 at 400 V rated value	0.09 kW
• at AC-43	
— at 400 V rated value	90 W
— at 500 V rated value	120 W
— at 690 V rated value	180 W
no-load switching frequency	3 600 1/h
operating frequency	
• at AC-41 according to IEC 60947-6-2 maximum	750 1/h
• at AC-43 according to IEC 60947-6-2 maximum	250 1/h
Control circuit/ Control	
type of voltage	AC/DC
control supply voltage 1 at AC	
• at 50 Hz rated value	240 V
• at 50 Hz	110 ... 240 V
• at 60 Hz	110 ... 240 V
control supply voltage frequency	
• 1 rated value	50 Hz
• 2 rated value	60 Hz
control supply voltage 1 at DC	
• rated value	240 V
•	110 ... 240 V
holding power	
• at AC maximum	6 W
• at DC maximum	5.1 W
Auxiliary circuit	
number of NC contacts for auxiliary contacts	1
number of NO contacts for auxiliary contacts	1
number of NO contacts of instantaneous short-circuit trip unit for signaling contact	1
number of CO contacts of the current-dependent overload release for signaling contact	1
operational current of auxiliary contacts at AC-12 maximum	10 A
operational current of auxiliary contacts at DC-13 at 250 V	0.27 A
Protective and monitoring functions	
trip class	CLASS 10 and 20 adjustable
operating short-circuit current breaking capacity (I_{cs})	
• at 400 V rated value	53 kA
• at 500 V rated value	3 kA
• at 690 V rated value	3 kA
UL/CSA ratings	
full-load current (FLA) for 3-phase AC motor	
• at 480 V rated value	0.4 A
• at 600 V rated value	0.4 A

contact rating of auxiliary contacts according to UL	contacts 21-22, 13-14, 43-44 Q600 / A600, contacts 77-78 R300 / B300, contacts 95-96-98 R300 / D300
Short-circuit protection	
product function short circuit protection	Yes
design of short-circuit protection	electromagnetic
design of the fuse link	
<ul style="list-style-type: none"> • for short-circuit protection of the auxiliary switch required • for short-circuit protection of the signaling switch of the short-circuit release required • for short-circuit protection of the signaling switch of the overload release required 	fuse gL/gG: 10 A 6A gL/gG/400V 4A gL/gG/400V
Installation/ mounting/ dimensions	
mounting position	any
mounting position recommended	vertical, on horizontal standard DIN rail
fastening method	screw and snap-on mounting
height	170 mm
width	45 mm
depth	165 mm
Connections/ Terminals	
product component removable terminal for main circuit	Yes
product component removable terminal for auxiliary and control circuit	Yes
type of electrical connection	
<ul style="list-style-type: none"> • for main current circuit • for auxiliary and control circuit 	screw-type terminals screw-type terminals
type of connectable conductor cross-sections for main contacts	
<ul style="list-style-type: none"> • solid • finely stranded with core end processing 	2x (1.5 ... 6 mm ²), 1x 10 mm ² 2x (1.5 ... 6 mm ²)
type of connectable conductor cross-sections	
<ul style="list-style-type: none"> • for auxiliary contacts <ul style="list-style-type: none"> — solid — finely stranded with core end processing • for AWG cables for auxiliary contacts 	0.5 ... 4 mm ² , 2x (0.5 ... 2.5 mm ²) 0.5 ... 2.5 mm ² , 2x (0.5 ... 1.5 mm ²) 2x (20 ... 14)
Safety related data	
proportion of dangerous failures	
<ul style="list-style-type: none"> • with low demand rate according to SN 31920 • with high demand rate according to SN 31920 	40 % 50 %
B10 value with high demand rate according to SN 31920	3 000 000
failure rate [FIT] with low demand rate according to SN 31920	100 FIT
IEC 61508	
T1 value for proof test interval or service life according to IEC 61508	20 a
Electrical Safety	
protection class IP on the front according to IEC 60529	IP20
touch protection on the front according to IEC 60529	finger-safe
Communication/ Protocol	
product function bus communication	No
protocol is supported	
<ul style="list-style-type: none"> • AS-Interface protocol • IO-Link protocol 	No No
product function control circuit interface with IO link	No
Electromagnetic compatibility	
conducted interference	
<ul style="list-style-type: none"> • due to burst according to IEC 61000-4-4 • due to conductor-earth surge according to IEC 61000-4-5 • due to conductor-conductor surge according to IEC 61000-4-5 • due to high-frequency radiation according to IEC 61000-4-6 	4 kV main contacts, 2 kV auxiliary contacts 4 kV main contacts, 2 kV auxiliary contacts 2 kV main contacts, 1 kV auxiliary contacts 0.15-80Mhz at 10V
field-based interference according to IEC 61000-4-3	10 V/m
electrostatic discharge according to IEC 61000-4-2	8 kV
conducted HF interference emissions according to	150 kHz ... 30 MHz Class A

CISPR11	
field-bound HF interference emission according to CISPR11	30 ... 1000 MHz Class A
Supply voltage	
Supply voltage required Auxiliary voltage	No
Display	
number of LEDs	2
Approvals Certificates	
General Product Approval	



[Confirmation](#)



EMV	Functional Safety	Test Certificates	Marine / Shipping
-----	-------------------	-------------------	-------------------



[Type Test Certificates/Test Report](#)



other	Dangerous Good	Environment
-------	----------------	-------------

[Confirmation](#)

[Transport Information](#)

[Environmental Confirmations](#)

Further information

Information on the packaging

<https://support.industry.siemens.com/cs/ww/en/view/109813875>

Information- and Downloadcenter (Catalogs, Brochures,...)

<https://www.siemens.com/ic10>

Industry Mall (Online ordering system)

<https://mall.industry.siemens.com/mall/en/en/Catalog/product?mlfb=3RA6120-1AP32>

Cax online generator

<http://support.automation.siemens.com/WW/CAXorder/default.aspx?lang=en&mlfb=3RA6120-1AP32>

Service&Support (Manuals, Certificates, Characteristics, FAQs,...)

<https://support.industry.siemens.com/cs/ww/en/ps/3RA6120-1AP32>

Image database (product images, 2D dimension drawings, 3D models, device circuit diagrams, EPLAN macros, ...)

http://www.automation.siemens.com/bilddb/cax_de.aspx?mlfb=3RA6120-1AP32&lang=en

Characteristic: Tripping characteristics, I²t, Let-through current

<https://support.industry.siemens.com/cs/ww/en/ps/3RA6120-1AP32/char>

Further characteristics (e.g. electrical endurance, switching frequency)

<http://www.automation.siemens.com/bilddb/index.aspx?view=Search&mlfb=3RA6120-1AP32&objecttype=14&gridview=view1>

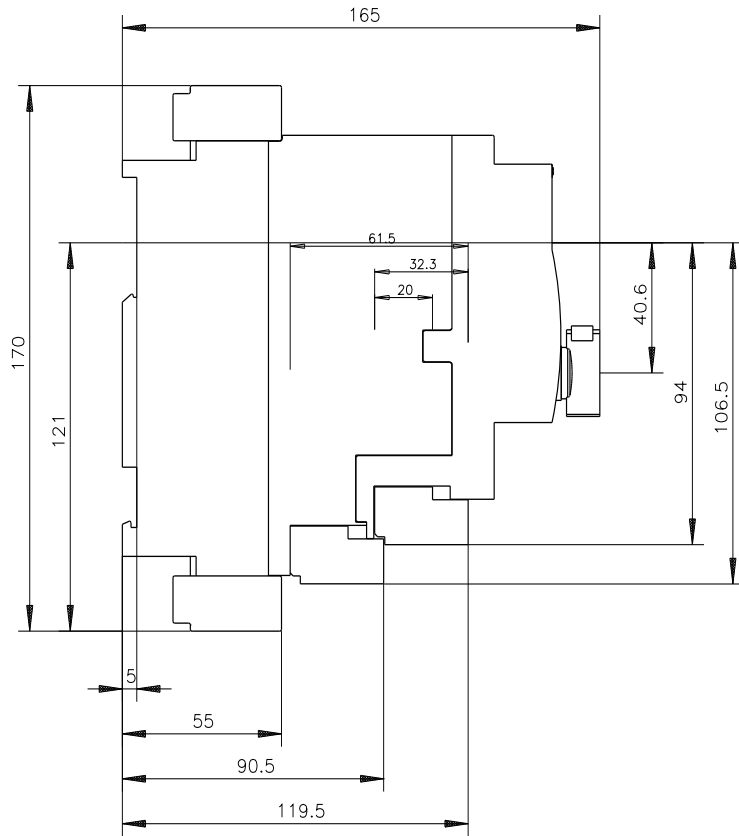
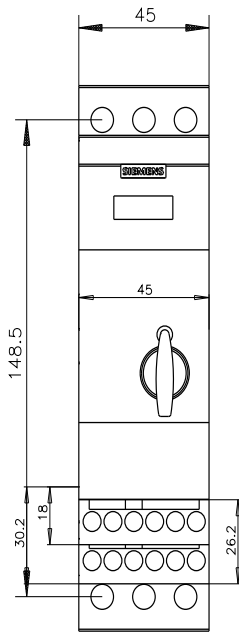

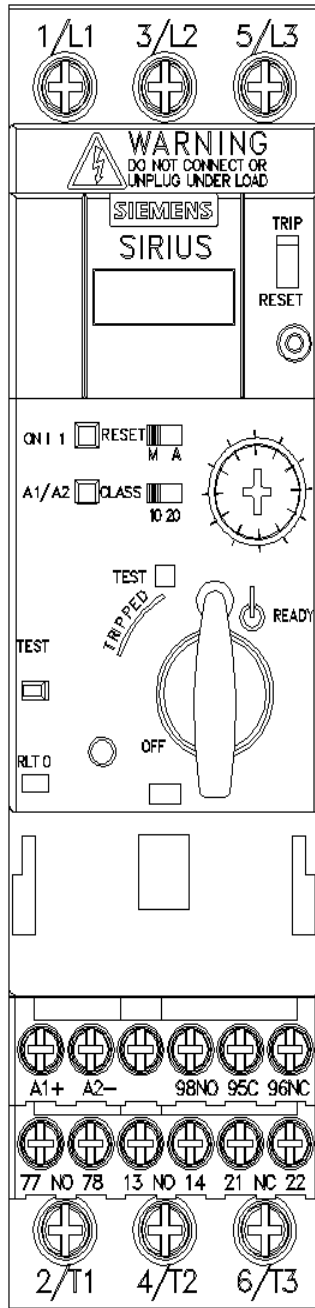

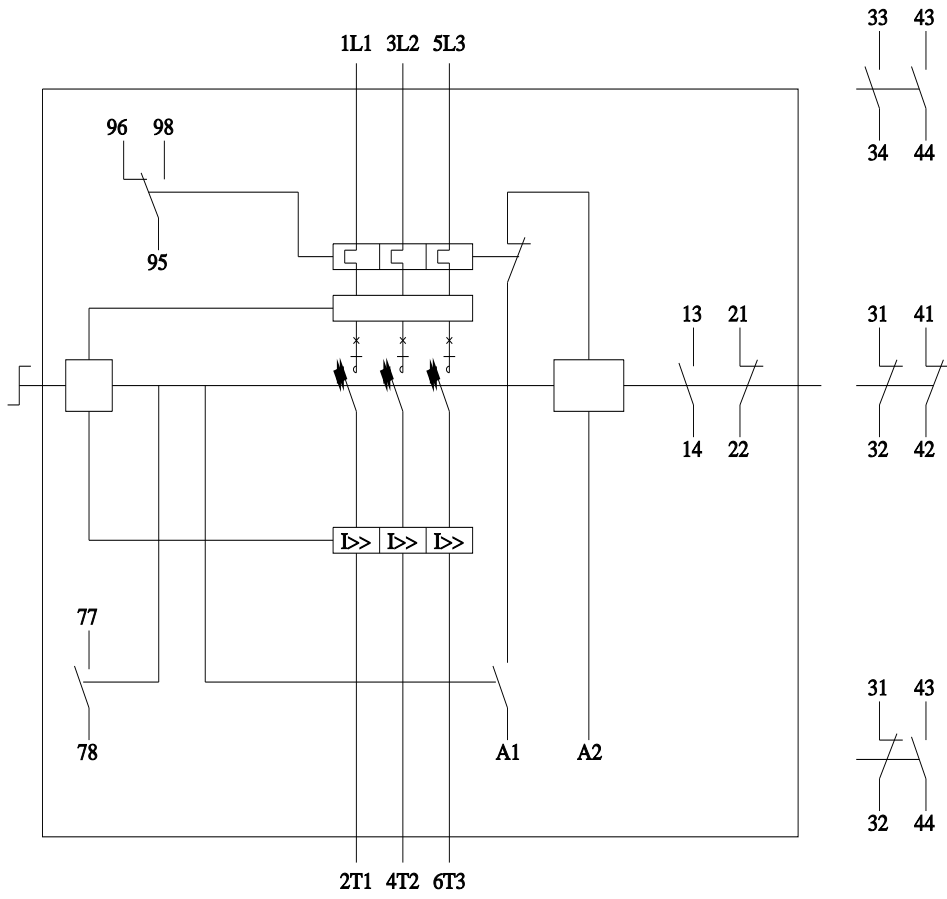

last modified:

3/11/2024 