

# Product data sheet

Specifications

**SQUARE** D

**Green Premium™**



Load center, QO, 1 phase, 8 spaces, 16 circuits, 200A convertible main breaker, NEMA3R, feedthru lugs, UL

QO1816M200FTRB

**Product availability : Stock - Normally stocked in distribution facility**

**Price\* : 863.00 USD**

## Main

Marketing Trade Name	QO
Product Type	Load Center
Enclosure Type	Weatherproof enclosure
Cover Type	Surface cover

## Complementary

Load Center Type	Main breaker
Rated Current	200 A
Number of Spaces	8
Max Short Circuit Current Rating	22 kA
Maximum Number of Single Pole Circuits	16
Maximum Number of Tandem Breakers	8
Number of Phases	1 phase
Voltage Rating	120/240 V AC
Wire Size	AWG 4...250 kcmil aluminium/copper
Ground Bar	Grounding bar (ordered separately)
Electrical Connection	Feed-thru lugs
Wiring Configuration	3-wire
Busbar Material	Tin plated copper busbar
Enclosure Material	Welded galvanized steel
Surface Finish	Baked enamel Gray
Box Number	6R
Height	29.84 in (758 mm)
Width	14.76 in (375 mm)

\* Price is "List Price" and may be subject to a trade discount – check with your local distributor or retailer for actual price.

## Environment

Enclosure Rating	NEMA 3R outdoor
Ambient Air Temperature for Operation	23 °F (-5 °C) 104 °F (40 °C)
Product Certifications	UL Listed

## Ordering and shipping details

Category	00101 - QO 1PH LC,2-8CKT,NEMA 1,3R
Discount Schedule	DE3A
GTIN	785901868187
Nbr. of units in pkg.	1
Package weight(Lbs)	32.10 lb(US) (14.56 kg)
Returnability	Yes
Country of origin	US

## Packing Units

Unit Type of Package 1	PCE
Package 1 Height	31.30 in (79.502 cm)
Package 1 width	4.80 in (12.192 cm)
Package 1 Length	15.50 in (39.37 cm)
Unit Type of Package 2	PAL
Number of Units in Package 2	21
Package 2 Weight	702.00 lb(US) (318.422 kg)
Package 2 Height	38.00 in (96.52 cm)
Package 2 width	40.00 in (101.6 cm)
Package 2 Length	48.00 in (121.92 cm)

## Offer Sustainability

Sustainable offer status	Green Premium product
California proposition 65	WARNING: This product can expose you to chemicals including: Lead and lead compounds, which is known to the State of California to cause cancer and birth defects or other reproductive harm. For more information go to <a href="http://www.P65Warnings.ca.gov">www.P65Warnings.ca.gov</a>
REACH Regulation	<a href="#">REACH Declaration</a>
REACH free of SVHC	Yes
EU RoHS Directive	Compliant <a href="#">EU RoHS Declaration</a>
Toxic heavy metal free	Yes
Mercury free	Yes
RoHS exemption information	<a href="#">Yes</a>
China RoHS Regulation	<a href="#">China RoHS declaration</a> Pro-active China RoHS declaration (out of China RoHS legal scope)

## Contractual warranty

Warranty	18 months
----------	-----------

Dimensions

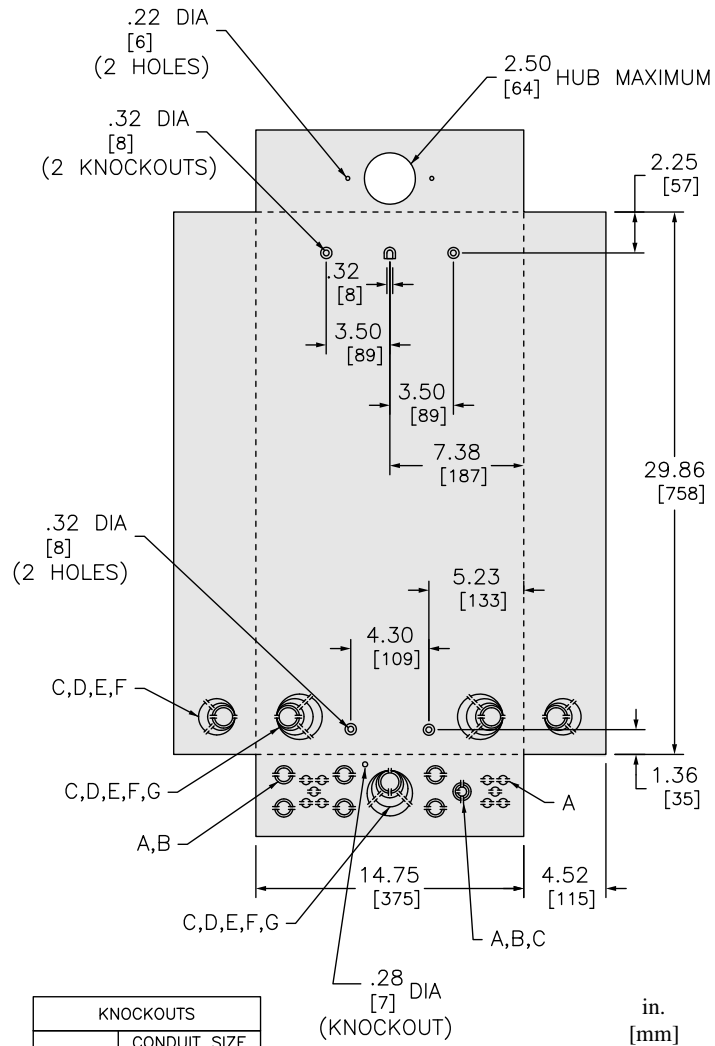

All dimensions are approximate.  
 Also refer to technical drawings and documentation.

Wiring Diagram

---

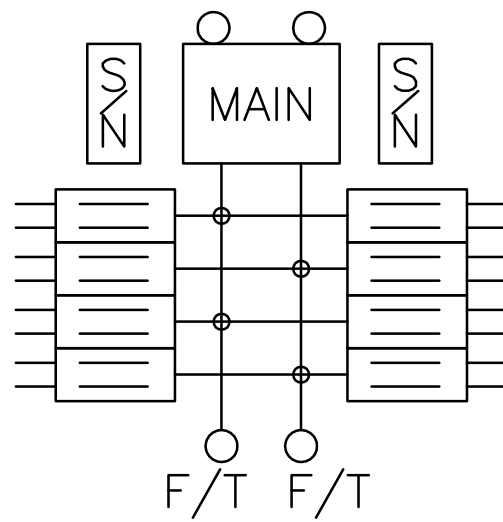

QO1816M150FTRB  
QO1816M200FTRB