



High Reliability
Maintenance-free
Environmentally Friendly



Powering Business Worldwide

Dry-type Transformer



Eaton Cooper Power Systems, a global manufacturer, famous for its market leadership and technical innovation, provides most safe and reliable power transmission and distribution to worldwide power utilities, industries and enterprises, public institutions and homes. We provides a wide range of forward-looking products and solutions for Distributed Generation Installations, Power Quality, Outage Management, Distribution Automation, Environmental protection.

Products include transformer, regulator, capacitor, MRPs, components, cutouts, disconnect, tors, overhead switchgear, RMU, VCB, and smart grid solutions, etc., which not only applied widely to substation, outdoor overhead, underground, and in-plant medium voltage distribution systems, but also to railway, solar and wind field.

We are committed to constantly improving electrical distribution for end-users to solve problems, to achieve a more reliable and safer power systems with better power quality. Your success drives us to move forward continuously and we listen to your sound for requirement.



CONTENTS

Features of Products.....	01
Technical Specification.....	02
Outline Drawings.....	03
Technical Data.....	04
Manufacturing.....	05-08
Optional Accessories.....	09-10
Quality Control.....	11
Customer Reference List.....	12

Dry-type Transformer

Features of Products

1. Lifting lug
2. LV terminal
3. Core
4. HV terminal
5. HV winding
6. Tapping terminal
7. LV windings
8. Base

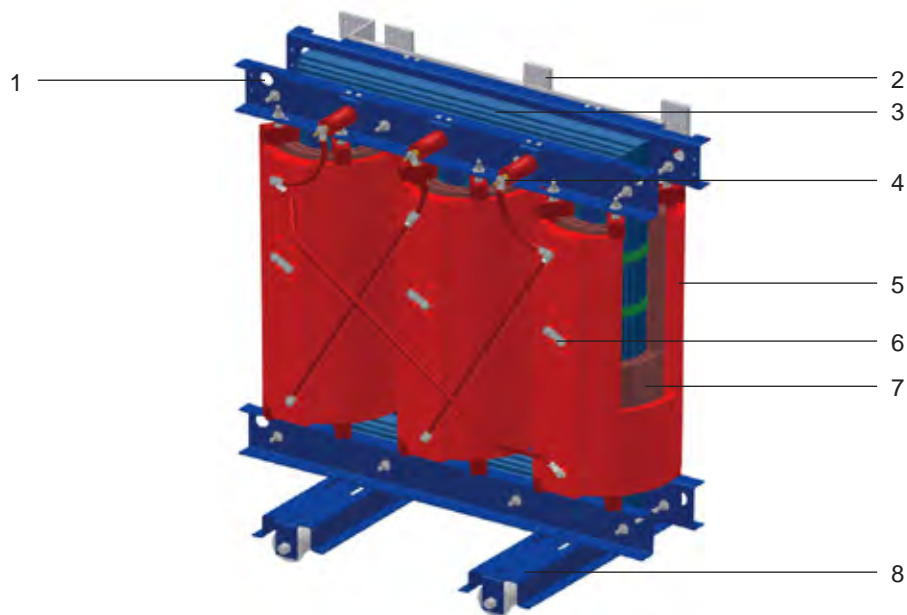

Non-Flammable

The insulating materials will not self-ignite and are self-extinguishing.

Efficient & Quiet

Transformer have low losses and low sound level.

Environmentally Safe

Units are non-polluting and require little maintenance.

Dielectric Integrity

Transformer are free of partial discharge and withstand high Basic Impulse Levels.

High Short-Circuit Strength

Units are resistant to short-circuit forces.

Hermetically Sealed

Transformer are impervious to humidity and most common industrial contaminants.

Low Installation Cost

Transformer can be installed close to the load center without costly vaults, dikes and special ventilation.

Conserve Valuable Space

Designs are compact and light weight

Technical Specifications

- Voltage Range: Up to 35kV(including dual voltages)
- Capacity: 30 to 40000kVA(AN)
- Taps: $\pm 2 \times 2.5\%$ are standard (other options available)
- Frequency: 50Hz or 60Hz
- Phases: Single or Three-Phase
- Vector Group: Dyn11, Yyn0 or others
- Cooling: AN or AF
- Insulation Class: F or H
- Insulation Level:

Voltage	6/10kV	20kV	35kV
P.F.test	35kV	50kV	70kV
B.I.L.test	75kV	125kV	170kV
- Protection Enclosure Grade: IP00, IP20, IP23 or as required
- Service Condition: Altitude, not exceeding 1000m.
Ambient temperature, not exceeding 40°C
- Standards:
 - GB1094 «Power Transformer»
 - IEC60076 «Power Transformer»
- Customizable according to special customer demands.



Models and Symbols

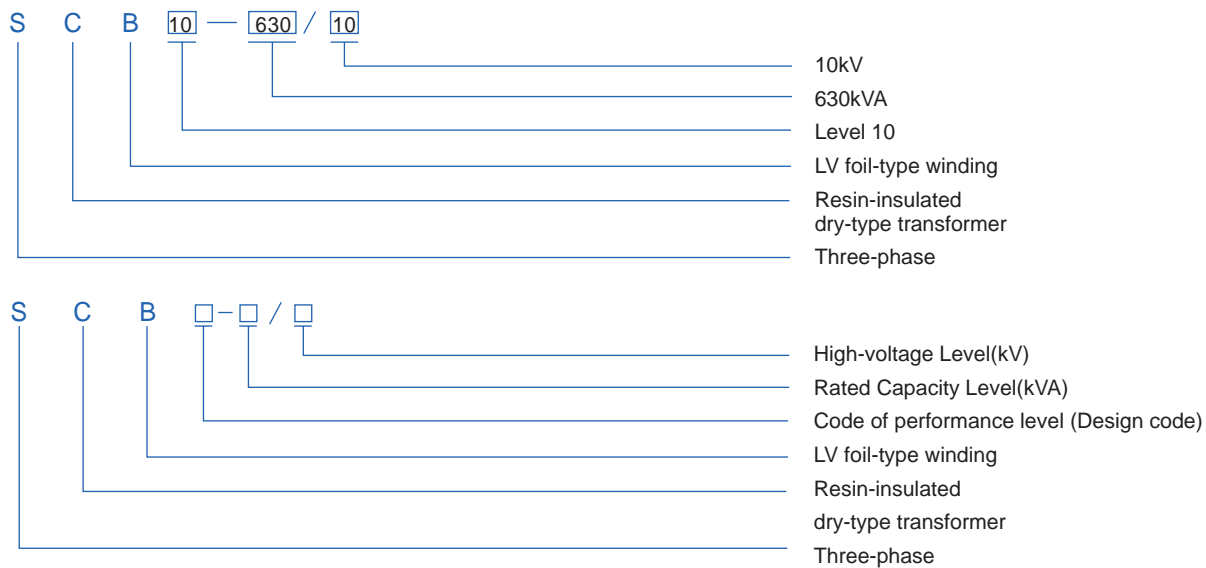

Dry-type Transformer

Technical Data

Voltage class 10kV, 30 up to 2500 kVA

Model	Voltage Class (kV)	Power [kVA]	Uk [%]	P0 [W]	Pk at 120°C[W]	Lwa [(db(A))]	Length [mm] IP00/IP20	Width [mm] IP00/IP20	Height [mm] IP00/IP20	Total Weight [kg] IP00/IP20	Roller distance [mm]
SC10-30/10		30	4	190	710	50	900/1650	760/1450	1000/2000	380/680	550
SC10-50/10		50	4	270	1000	55	1000/1650	760/1450	1100/2000	560/860	550
SC10-63/10		63	4	320	1170	55	1100/1650	760/1450	1100/2000	600/900	550
SC10-80/10		80	4	370	1380	55	1100/1650	760/1450	1100/2000	690/990	550
SCB10-100/10	11	100	4	400	1570	55	1100/1650	760/1450	1150/2000	780/1080	550
SCB10-125/10		125	4	470	1850	55	1200/1650	760/1450	1200/2000	1010/1310	550
SCB10-160/10	10.5	160	4	540	2130	58	1200/1650	760/1450	1200/2000	1120/1420	660
SCB10-200/10	10	200	4	620	2530	58	1300/1650	760/1450	1200/2000	1360/1660	660
SCB10-250/10	6.3	250	4	720	2760	58	1350/1950	760/1600	1250/2000	1480/1830	660
SCB10-315/10	6	315	4	880	3470	60	1350/1950	760/1600	1250/2000	1550/1900	660
SCB10-400/10		400	4	980	3990	60	1350/1950	760/1600	1250/2000	1680/2030	660
SCB10-500/10		500	4	1160	4880	60	1350/1950	760/1600	1250/2000	1900/2250	660
SCB10-630/10		630	4	1340	5880	62	1600/2350	850/1650	1400/2000	2740/3240	660
SCB10-630/10		630	6	1300	5960	62	1600/2350	850/1650	1400/2000	2400/2900	660
SCB10-800/10		800	6	1520	6960	64	1600/2350	850/1650	1500/2000	2950/3450	820
SCB10-1000/10		1000	6	1770	8130	64	1700/2350	850/1650	1550/2000	3320/3820	820
SCB10-1250/10		1250	6	2090	9690	65	1700/2350	850/1650	1650/2000	3770/4270	820
SCB10-1600/10		1600	6	2450	11730	66	1900/2650	850/1850	1750/2500	4680/5230	820
SCB10-2000/10		2000	6	3050	14450	66	1950/2650	1200/1850	1800/2500	5430/5980	820
SCB10-2500/10		2500	6	3600	17170	68	2100/2650	1200/1850	1950/2500	6580/7130	1070

Voltage class 20kV, 315 up to 2500 kVA

Model	Voltage Class (kV)	Power [kVA]	Uk [%]	P0 [W]	Pk at 120°C[W]	Lwa [(db(A))]	Length [mm] IP00/IP20	Width [mm] IP00/IP20	Height [mm] IP00/IP20	Total Weight [kg] IP00/IP20	Roller distance [mm]
SCB10-315/20		315	6	972	4085	60	1600/2350	850/1650	1500/2000	2060/2560	660
SCB10-400/20		400	6	1152	4845	60	1600/2350	850/1650	1500/2000	2210/2710	660
SCB10-500/20		500	6	1350	5795	60	1650/2350	850/1650	1550/2000	2620/3120	660
SCB10-630/20		630	6	1530	6840	62	1700/2350	850/1650	1600/2000	2720/3220	820
SCB10-800/20	20	800	6	1755	8265	62	1800/2350	1000/1650	1650/2000	3120/3620	820
SCB10-1000/20		1000	6	2070	9785	64	1800/2350	1000/1650	1850/2000	3600/4100	820
SCB10-1250/20	22	1250	6	2385	11543	64	2000/2650	1000/1850	1950/2500	4350/4900	820
SCB10-1600/20		1600	6	2790	13870	66	2100/2650	1000/1850	2000/2500	5650/6200	820
SCB10-2000/20		2000	6	3240	16388	66	2200/3000	1200/1850	2050/2500	6520/7210	1070
SCB10-2500/20		2500	6	3870	19380	68	2300/3000	1200/1850	2100/2500	7720/8410	1070
SCB10-2000/20		2000	8	3240	17860	66	2200/3000	1200/1850	2000/2500	6070/6760	1070
SCB10-2500/20		2500	8	3870	21280	68	2500/3000	1200/1850	2100/2500	8000/8690	1070

Voltage class 34.5kV, 315 up to 4000 kVA

Model	Voltage Class (kV)	Power [kVA]	Uk [%]	P0 [W]	Pk at 120°C[W]	Lwa [(db(A))]	Length [mm] IP00/IP20	Width [mm] IP00/IP20	Height [mm] IP00/IP20	Total Weight [kg] IP00/IP20	Roller distance [mm]
SCB10-315/35		315	6	1179	4513	60	1800/2650	1000/1850	1800/2500	2370/2920	820
SCB10-400/35		400	6	1377	5415	60	1800/2650	1000/1850	1800/2500	2810/3360	820
SCB10-500/35		500	6	1620	6650	60	1900/2650	1000/1850	1850/2500	3410/3960	820
SCB10-630/35		630	6	1863	7695	62	1900/2650	1000/1850	1850/2500	3510/4060	820
SCB10-800/35	38.5	800	6	2160	9120	62	2000/2650	1000/1850	1950/2500	4480/5030	820
SCB10-1000/35		1000	6	2430	10450	64	2100/3000	1200/1850	2100/2500	5240/5930	820
SCB10-1250/35	35	1250	6	2835	12730	64	2200/3000	1200/1850	2200/2500	6220/6910	820
SCB10-1600/35	34.5	1600	6	3150	15485	66	2300/3000	1200/1850	2250/2500	7370/8060	1070
SCB10-2000/35		2000	6	3825	18240	66	2450/3200	1200/1850	2250/2500	8290/9110	1070
SCB10-2500/35		2500	6	4455	21850	68	2550/3200	1200/1850	2300/2500	9650/10470	1070
SCB10-3150/35		3150	6	11620	28090	70	2950/3900	1400/2150	2400/3000	11780/12780	1300
SCB10-4000/35		4000	6	12450	33840	70	3000/3900	1400/2150	2600/3000	12980/13980	1300

Outline drawings

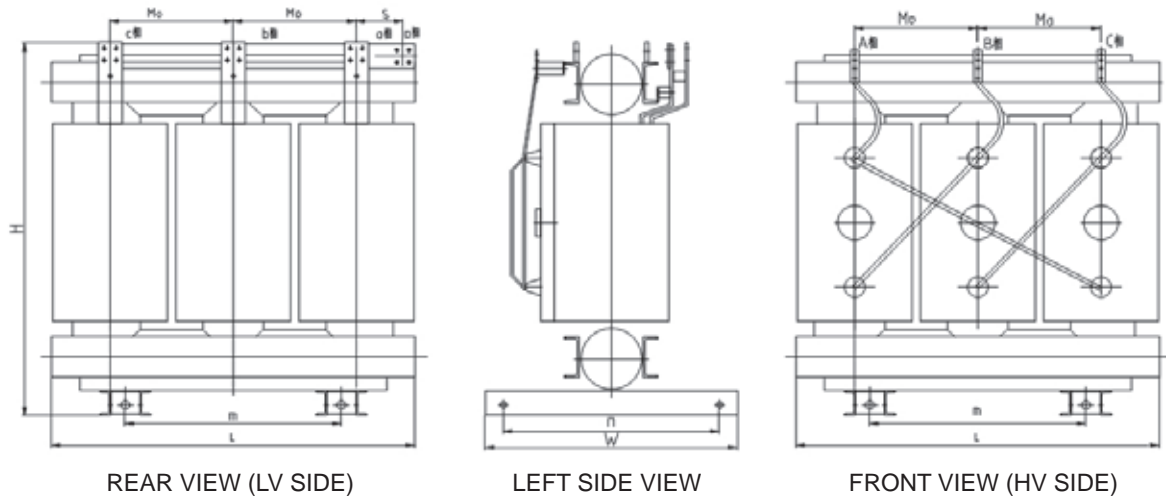

IP20 Enclosure Dimensions

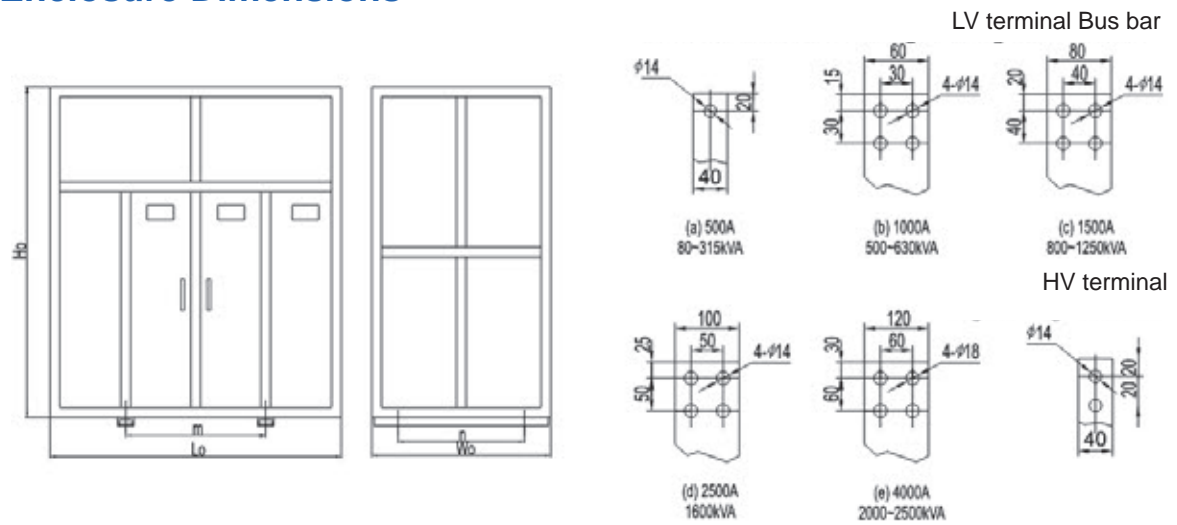

Dry-type Transformer

Manufacturing CORE



GEORG lamination cut-to-length line

The core is the heart of transformer. Through the first-class equipment, advanced process and high-quality material, our core is of high quality to greatly reduce the no-load losses and noise of transformer.



GEORG stacking line

We adopt the full-automatic silicon steel sheet cutter of German GEORG Co. By controlling through computer program, it has a high cutting precision and no burr, and has the function of multi-end feeding, automatic stacking collection and step lap. It can reduce the number of vibration at cutting, so that the crystal grain structure is maintained with less variation of finished silicon steel sheet.

Manufacturing CORE



GEORG stacking table

Our core has an approximate circular section. Silicon steel sheet is cut fully-oblique at 45°. The joint between core column and yoke iron is of step lap structure. These measures improve the magnetic field distribution of core, and reduce the consumption of materials and energy. We also adopt the core inverting/lap/ assembling table of German GEORG Co. It assembles the core column and yoke iron into epsilon-shaped core, and significantly improves the processing quality and production efficiency of core.

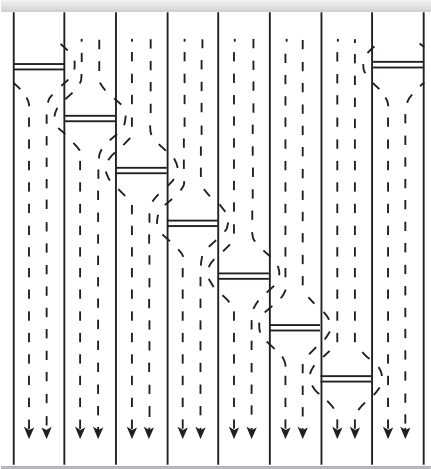

Magnetic flux distribution on the connections with step-lap

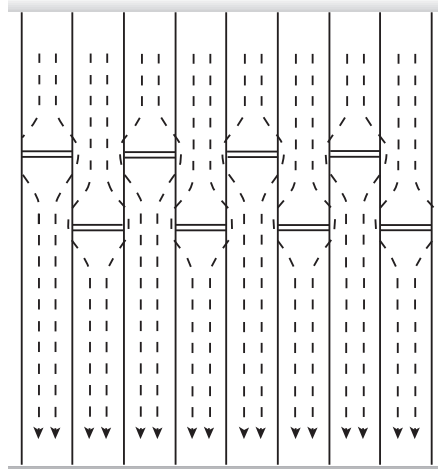

Magnetic flux distribution on the connections with traditional-lap

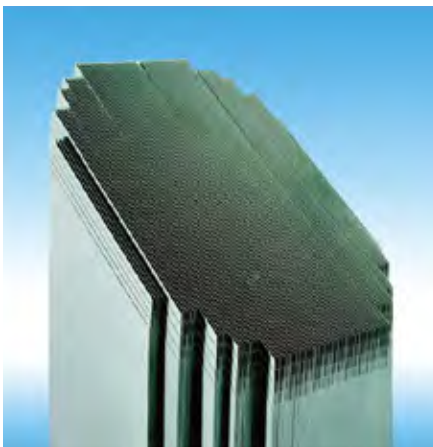

Step-lap core

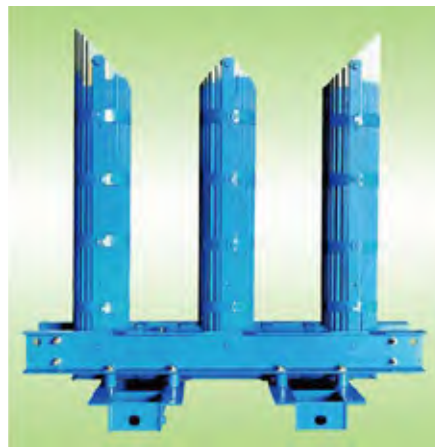

"E" core finished without upper yoke

Dry-type Transformer

Manufacturing WINDINGS

Computer-controlled HV automatic winding machines constant tension and automatic wire laying function were imported from STOLLBERG, a German company. The HV windings are made of copper electromagnetic wire and insulated with fiberglass mats through segmented cylindrical structure, and thus with a low voltage between layers and strong over-voltage resistance. The winding of larger capacity has a heat-radiating air passage to make a good heat radiation.

Eaton also produces LV copper-foil windings. The advantage of foil winding is that the current density can distribute itself freely along the width of the conductor and have strong short-circuit resistance. LV foil is closely through highly-purified round-edge foil strip and insulating material pre-saturated in epoxy resin. LV foil winding machine is the newest product of STOLLBERG. Controlled by a computer module, the machine can maintain constant tension, wipe off any debur and rectify deviations automatically.



HV winding machine from Stollberg



LV foil winding from Stollberg



Manufacturing CASTING

The winding is moved into the vacuum casting chamber of epoxy resin vacuum casting equipment to dry after preheating, the moisture/gas in the insulation are removed in the vacuum casting procedure. Meanwhile, the imported chemical materials (e.g. epoxy resin and hardener) are continuously prepared in the separate vessels. After the preparation process is finished, all of the materials are pumped into a static mixer at the ratio preset by the precise computer measuring system, and then cast into the molds. After the completion of casting, the coils are

cured in an oven to form strong solid coils under high temperature.

We adopt the casting equipment introduced from HUBERS, a German company. It applies the patented technologies (e.g. thin-film deaeration and static mixing). The static mixing technology is significantly superior to dynamic one in the consistent physical/chemical property of material mixture (e.g. viscosity and chemical reaction degree).



Resin Vacuum Casting System from Hubers

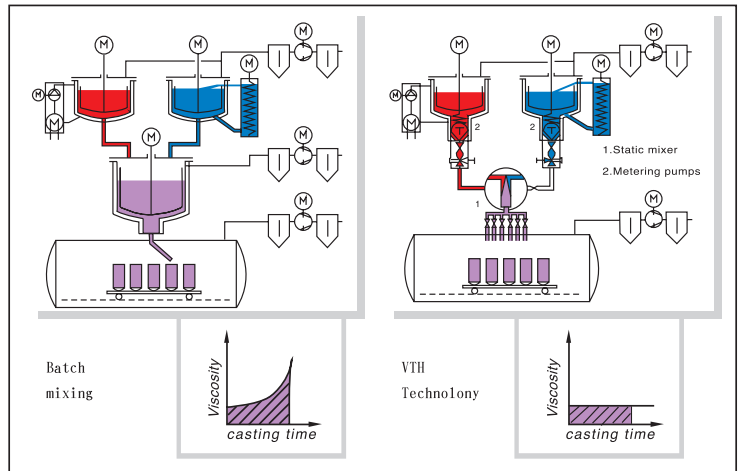

Difference between static mixing technology & batch mixing technology



LV foil Windings



HV Windings

Dry-type Transformer

Optional Accessories

Steel-plate protective enclosure



The steel-plate enclosure is processed from high-quality cold-rolled steel plate through three numerical control equipment (i.e. numerical control cutter, numerical control puncher and numerical control plate bender). The surface of enclosure panel is treated through phosphorization and plastic spraying, and thus possesses a very high corrosion resistance. The steel-plate enclosure has various advantages (e.g. beautiful exquisite appearance, good ventilation, simple fast installation, and convenient transportation). Its assembled structure has a high mechanical strength. It can be easily assembled on the scene, and there are access door and ventilating hole in its front and at its back. The color of steel-plate enclosure is computer gray (RAL7032) or customizable according to customer demand.

Aluminum-alloy protective enclosure



The aluminum-alloy enclosure is processed mainly from aluminum-alloy polished plate. It has a beautiful appearance and good corrosion resistance. It can be easily assembled on the scene, and there are access door in its front and at its back.

The protective enclosure provides safety shielding for charged position at a protective class of IP20, IP23 and above. IP20 enclosure can prevent the entry of solid impurities of >12mm diameter; and IP23 enclosure can additionally prevent the inflow of water droplet within the range at a 60°angle to of perpendicular line, and is applicable for outdoor use.

Optional Accessories

Air-cooling system



The transformer can be cooled by two modes: air natural cooling (AN) and air forced cooling (AF). Forced-air AF output of the transformer is up to 140% of the self-cooled rating, should be used only for emergency non-recurring loads, and but is not recommended for long-term running.

Temperature Controller



The temperature is controlled by means of sensor provided on each transformer. The sensor (Pt100) are installed in the LV winding. The digital controller shows the operating temperature of each LV winding, sequentially. The temperature controller performs the following functions of three-phase winding during transformer running: automatically switch the cooling fans on at 100°C and off at 80°C , it will send an over-temperature alarm at 130°C , and will send emergency shutdown trip signal at 150°C . and sensor fault alarm.

Dry-type Transformer

Quality Control



Transformer Inspection and Test Center

Eaton Electric quality control was carried out according to ISO9001 quality management standard and production standard, there are many quality engineers working for IQC, PQC, FQC and OQC. All product should be inspected and tested by operator, auditor and inspector according to the production standards and requirements before it been transported to the next production process, the failed product will be rejected. The product's quality and reliability are ensured by our strict management procedure, serious working attitude and advanced testing equipments.



Impulse Test System



Transformer Load Loss Test System



Micro-ohm Meter WR50-12

Test Item	Test Type	Test Item	Test Type
Winding resistance measurements	Routine test	Induced-voltage test	Routine test
Ratio and phase-relation tests	Routine test	Partial discharge measurements	Routine test
No-load loss and excitation current measurements	Routine test	Sound level measurements	Type test
Load loss and impedance measurements	Routine test	Lightning impulse test	Type test
Insulation resistance measurements	Routine test	Temperature rise test	Type test
Applied-voltage test	Routine test	Short-circuit withstand test	Special test

Customer Reference List



P&G Philippines
AES Philippines
Marriot Hotel Philippines

CitibankPhilippines
ZTE China
Tencent China

MTR HK
Abbott Malaysia
Goodyear Indonesia

Eaton is a power management company with 2015 sales of \$20.9 billion. Eaton provides energy-efficient solutions that help our customers effectively manage electrical, hydraulic and mechanical power more efficiently, safely and sustainably. Eaton has approximately 97,000 employees and sells products to customers in more than 175 countries. For more information, visit www.eaton.com.cn

Cooper Electronic Technologies (Shanghai) Co.,Ltd.

D2 Plant No.38 Dongsheng Road, East Area of
Zhangjiang High-Tech Park, Shanghai, China 201201
www.cooperpowersystems.com
www.eaton.com
B201-16022.January 2016.Rev01

Eaton and Cooper Power Series
are registered trademarks.
All other trademarks are property
of their respective owners.