

# Disconnect and oil circuit recloser bypass switches; regulator and current transformer bypass switches

## Contents

Description	Page
D-73 Distribution-Class Disconnect Switch . . . . .	2
M-72 Station-Class Disconnect Switch . . . . .	4
H-72 Station-Class Disconnect Switch . . . . .	6
D73-3P Distribution-Class Oil Circuit Recloser Bypass Switch . . . . .	8
M95-3P Station-Class Oil Circuit Recloser Bypass Switch . . . . .	10
Oil Circuit Recloser Station-Class Fused Bypass Combinations For Substation Mounting. . . . .	12
HB-65/HC-65 Station-Class Voltage Regulator Bypass Switch . . . . .	14
M-72 Station-Class Bypass Switch . . . . .	16
H72-3P Station-Class Bypass Switch . . . . .	18
HB-65 Current Transformer Bypass Switch . . . . .	20



*Powering Business Worldwide*

## Introduction

Eaton's Cooper Power™ series Kearney™ disconnect and oil circuit recloser bypass switches feature all copper bar current-carrying parts, providing uniform strength and conductivity with no hidden defects. Silver washers between the blade assembly and hinge act as a bearing, ensuring easy blade opening, even after long exposure to contaminated atmospheres. Eaton's Cooper Power series H-72 switch has silver inlays blazed to the hinge and jaw stationary contacts. The truss-type blade assembly with wide hinge and formed channel blades assures proper blade alignment during closing, even with applied side forces. The positive blade latch prevents nuisance openings and opening under fault conditions. The positive pryout affords easy opening under icing conditions. Eaton's Cooper Power series D-73, M-72 and H-72 switch models feature a 90° field removable stop. The stop pin can be removed if 180° blade travel is required. Tinned terminal pads accommodate either bronze or aluminum terminals.

Eaton's Kearney regulator and current transformer bypass switches feature sequenced, make before break operation in both 600 A and 1200 A ratings, minimizing the possibility of operator error. The single-pull operation of the 600 A ratings both bypasses and disconnects the regular or current transformer, or reconnects them to the line. The two-pull operation of 1200 A ratings minimizes the operating effort of these heavy-duty switches. An arcruptor or snaphorn provided on regulator bypass switches interrupts the regulator exciting current and prevents arcing and damage to the switch contacts when disconnecting the regulator. Reverse loop contacts on 600 A ratings increase contact pressure and minimize the possibility of contact damage when subjected to high fault current.

## D-73 distribution-class disconnect switch

Eaton's D-73 distribution-class, single pole, single throw disconnect switches provide a durable switch for line sectionalizing or isolating equipment on distribution circuits. These switches are quality constructed to ensure stable high current capability and full thermal capacity under the required duties of today's load and short circuit conditions.

**Current Ratings:** High current carrying capacity of 600 and 900 A continuous and 40 kA momentary.

**Blade Design:** Truss-type construction of formed copper bars has increased width at hinge for greater rigidity, thus minimizing side deflection and maintaining positive alignment when closing the switch.

**Formed Steel Channel Base:** Base and backstrap are rugged, hot dipped galvanized steel and have a dead- ending hole at each end.

**Minimum Current Interchanges:** Uniform conductivity is assured through utilization of hard drawn copper bar in forming one-piece stationary contacts and terminal pads. Design reduces current interchange points to a minimum.

**Contacts:** High pressure line type, both clip and hinge ends.

**Contact Surfaces:** 600 A ratings are silver to copper; 900 A are silver to silver. Silver washers between blade and stationary hinge act as a bearing to assure easy blade movement after long time exposure to contaminated atmospheres.

**Tin-Plated Terminal Pads:** Accommodate terminals for either aluminum or copper conductors.



Figure 1. D-73 single-pole disconnect switch.

**Positive Blade Lock and Pryout:** Blade latch prevents switch opening under high momentary current. Easy opening is assured through pryout assist.

**Insulators:** 2.25" B.C., characteristics available upon request.

**Vertical or Underhung Mounting:** Easily adaptable to single or double crossarm construction.

**90° Blade Stop:** Stop can be field removed for 180° blade travel.

**Special Applications:** Variations to meet specific customer requirements are available upon request.

Table 1. Terminal Assemblies



230026-S6	262013-S6		262224-1S6
			
<p><b>TWO-BOLT TINNED BRONZE PARALLEL GROOVE CLAMP</b> Secured with two galvanized steel bolts. Conductor range: #6 Solid to 397.5 MCM ASCR, 500 MCM Copper or 556 MCM Aluminum.</p>	<p><b>TWO CAPTIVE STAINLESS STEEL BOLTS</b> Factory installed, 1 3/4" long bolts, accepts compression terminals.</p>	<p><b>COMPRESSION TERMINAL</b> Refer to Catalog 325-21 for complete information relative to compression fitting required.</p>	<p><b>BRIDGE TYPE TWO-BOLT CLAMP</b> Accepts conductor sizes ranging from #4 Solid to 500 MCM copper or aluminum.</p>

Table 2. Dimensions and Ordering Information

Ratings	Catalog Number			Dimensions (inches), Reference Only								Approx. Net Wt. lbs.
	kV Max. Design	BIL kV	Mom. kA	600 A	900 A	B	C	D	E	H	P	
15.5	110	40	127700	127702CPS	11.88	15	25.5	7.5	7	9.75	8.5	33
25.8	125	40	127701CPS	127703CPS	11.88	15	25.5	7.5	8	10.75	9.5	37
25.8	150	40	127725	127704CPS	14.88	18	28.5	6	10	12.75	11.5	45
38.0	150	40	127738	127938CPS	14.88	18	28.5	6	10	12.75	11.5	45

Catalog Number Suffix Nomenclature

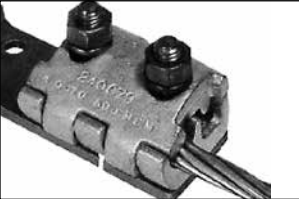
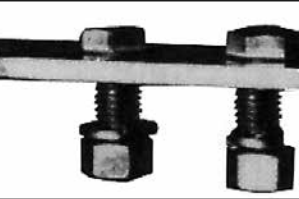
- A = 150 degree latch
- C = Captive terminal bolts 1-3/4" long, stainless steel on Nema two hole pad
- D = Bridge connector holes
- E = Bridge connectors on terminals
- H = .5" x 8" mounting coach bolts
- J = Channel base
- K = REA style backstrap with 2 bolts
- L = Loadbuster hook
- N = No backstrap
- P = Parallel groove clamp, Bronze
- R = REA backstrap with 4 bolts
- S = Slotted base
- Y = Cycloaliphatic insulators

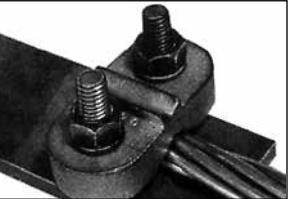
Example: 127700LR = 127700 with loadbuster hook, 4-bolt REA backstrap.

Example: 127725LR = 127725 with loadbuster hook, 4-bolt REA backstrap.

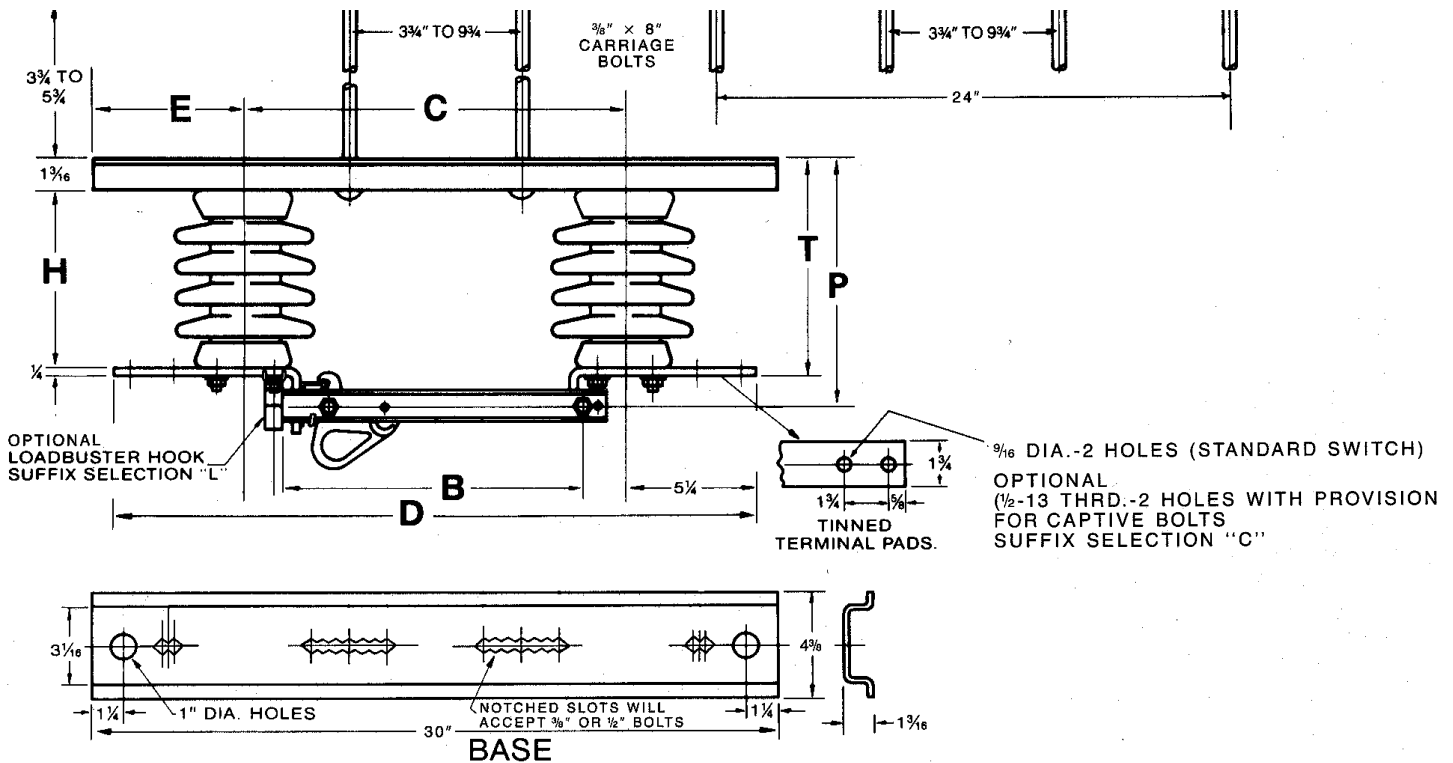

### M-72 station-class disconnect switch

Eaton's Cooper Power series Kearney M-72 single pole, single throw station-class hookstick-operated disconnect switch operate efficiently from terminal point to terminal point. Stability of the hard drawn copper channel formed blade construction and associated current carrying components are complemented by switch operating hardware for operating ease, and assurance of dependability under high thermal or momentary conditions.

**Rating:** Current carrying capacity of 600 A continuous and 40 kA momentary.

**Blade Design:** Truss-type construction of formed copper bars has increased width at hinge to assure greater rigidity. This maintains positive alignment during closing and guards against side thrust deflection. Blades are made of hard drawn copper, and are silver-plated at contact points.

**Hard Drawn Copper Contacts:** Uniform conductivity is assured through utilization of hard drawn copper in forming one-piece stationary contacts and terminal pads. Design reduces current interchange points to a minimum.

**Positive Blade Lock and Pryout:** Blade latch prevents opening under high momentary current conditions. Easy opening is assured through pryout assist.

**Silver to Silver Contacts:** Pressure line contact on clip and circular line contact on hinge are silver-plated. Silver plating on ends of blade provides silver to silver contact at current transfer points. Contact surfaces are self-cleaning, and self-wiping. Silver washers between blade and hinge act as a bearing to assure easy blade movement after long time exposure to contaminated atmospheres.

**Tin-Plated Terminal Pads:** Accommodates terminals for either aluminum or copper conductors.

**90° Blade Stop:** Furnished with switch. Stops can be field removed for 180° blade travel.

**Insulators:** Three inch B.C. ANSI® standard station post. Cycloaliphatic epoxy insulators also available. Characteristics available upon request.

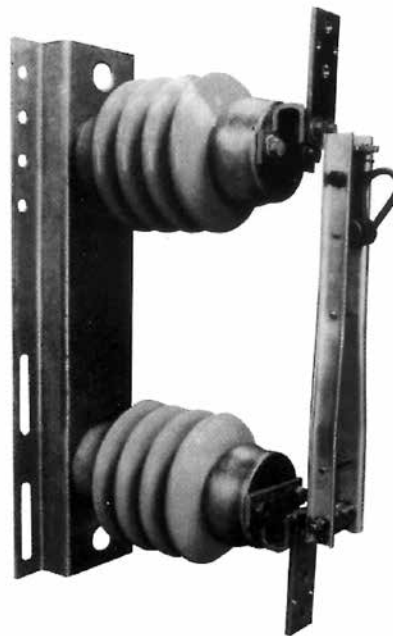

Figure 2. M-72 single-pole disconnect switch.

**Steel Channel Base:** Base is rugged, hot dipped galvanized formed steel with a dead-ending hole at both ends of the base.

**Vertical Mounting is Standard:** Available for underhung mounting if specified.

**Terminal Option:** Switches can be furnished with any terminal arrangement documented. Terminals are not included in the price of the switch.

**Special Applications:** Variations to meet specific customer requirements are available upon request.

**Stainless Steel Loadbreak Hooks:** For use with portable load interrupter tool available upon request.

Table 3. Terminal Assemblies

<p style="text-align: center;"><b>230026-S6</b></p>  <p><b>TWO-BOLT TINNED BRONZE PARALLEL GROOVE CLAMP</b> Secured with two galvanized steel bolts. Conductor range: #6 Solid to 397.5 MCM ACSR, 500 MCM Copper or 556 MCM Aluminum.</p>	<p style="text-align: center;"><b>262013-S6</b></p>  <p><b>TWO CAPTIVE STAINLESS STEEL BOLTS</b> Factory installed, 1 3/4" long bolts, accepts compression terminals.</p>	 <p><b>COMPRESSION TERMINAL</b> Refer to Catalog 325-21 for complete information relative to compression fitting required.</p>	<p style="text-align: center;"><b>262224-S6</b></p>  <p><b>BRIDGE TYPE TWO-BOLT CLAMP</b> Accepts conductor sizes ranging from #4 Solid to 666 6 MCM ACSR or 3/4" I.P.S. Copper.</p>
---	--	--	---

Table 4. Dimensions and Ordering Information

Base Type	Ratings				Catalog Number	3" B.C. Insulator T.R. No.	Dimensions (inches), Reference Only								Approx. Net Wt. lbs.
	kV Max. Design	Cont. A	Mom. kA	kV			A	B	C	D	E	F	G	H	
M-72	15.5	600	40	110	126636	205	15.75	15	26	10	9	25.5	15.75	13.5	53
P-72	15.5	600	40	110	126960	205	15.75	15	26	10	27	24	15.75	13.5	53
M-72	25.8	600	40	150	126638	208	18.75	18	29	14	12	28.5	18.75	17.5	78
P-72	25.8	600	40	150	126961CPS	208	18.75	18	29	14	30	27	18.75	17.5	78
M-72	38.0	600	40	200	126640CPS	210	24.75	24	35	18	18	34.5	22.75	21.5	117
P-72	38.0	600	40	200	126962CPS	210	24.75	24	35	18	36	33	22.75	21.5	117

Catalog Number Suffix Nomenclature  
 C = Captive terminal bolts, 1.75" long stainless steel on NEMA® two hole pad  
 E = Bridge connectors on terminals  
 I = Inverted construction for overhead use  
 L = Loadbuster hook  
 P = Parallel groove clamp, bronze  
 Y = Cycloaliphatic insulators

Example: 126636LP = 126636 with loadbuster hook and parallel groove clamps.

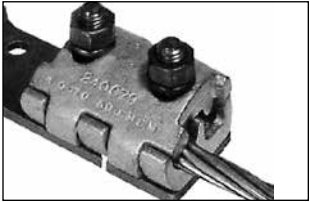
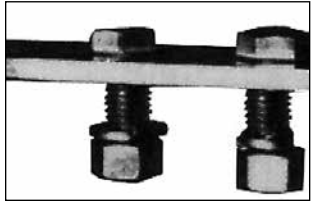
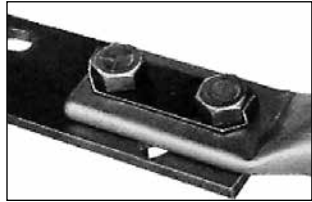
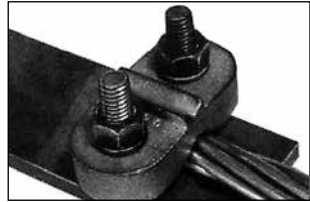
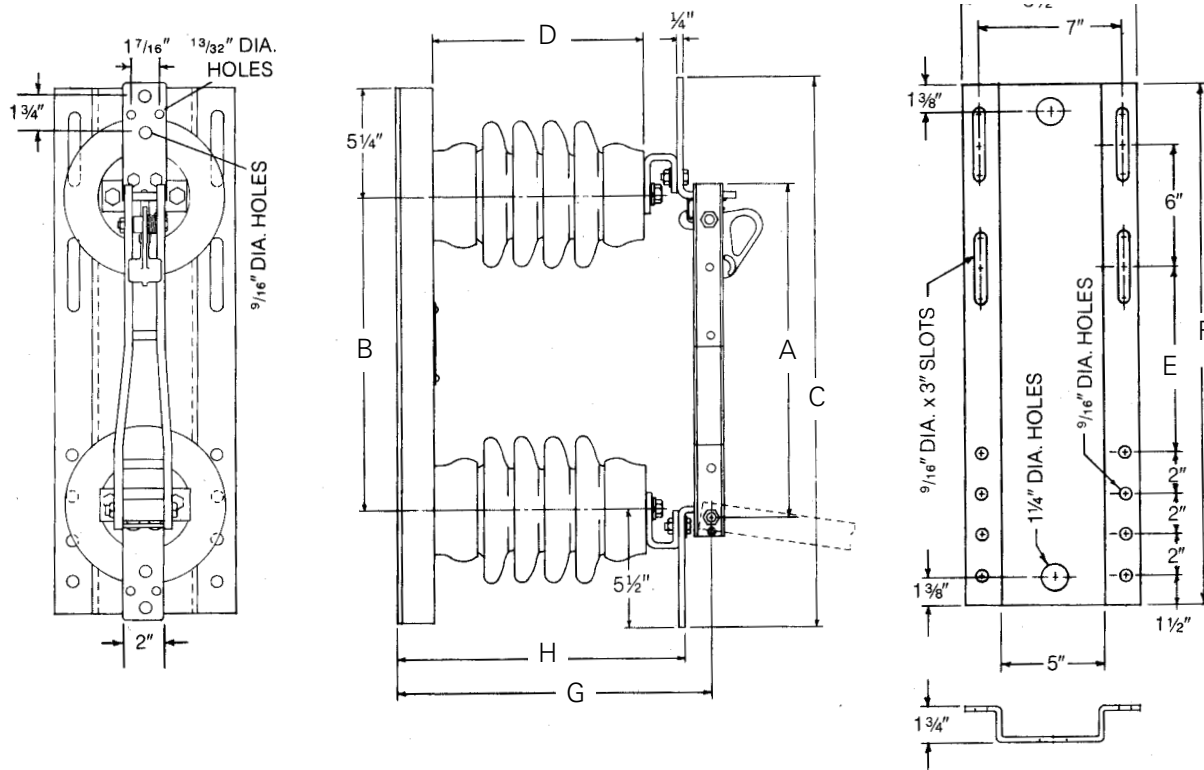

M-72 base dimensions

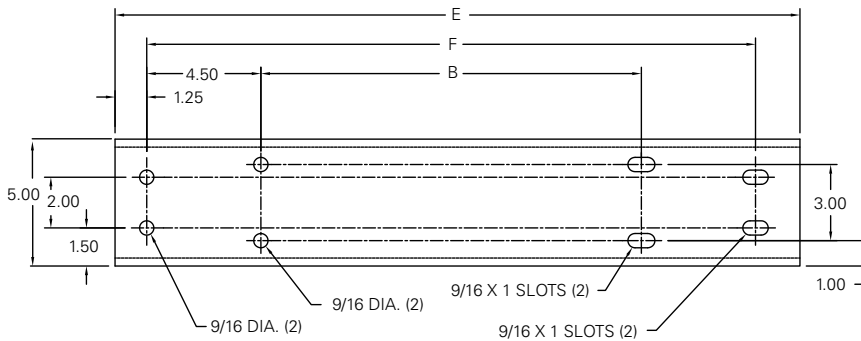

P-72 base dimensions

## H-72 station-class disconnect switch

The rugged construction of Eaton's Cooper Power series Kearney H-72 station-class disconnect switch assures long-term ease of operation and dependable service.

**Rating:** High current carrying capacity of 1200 A continuous and 61 kA momentary.

**Blade Design:** Truss-type construction of formed channel with increased width at hinge for greater rigidity. This assures minimum side thrust deflection and positive alignment during closing. Blades are silver-plated at contact points.

**Hard Drawn Copper Contacts:** Uniform conductivity is assured through utilization of copper bar one-piece stationary contacts and terminal pads. This design reduces current interchange points to a minimum.

**Silver to Silver Contacts:** High pressure line contact on clip and circular line contact on hinge. Stationary contacts have silver onlays and blade contacts are silver-plated. Contact surfaces are self-cleaning and self-wiping.

**Tin-Plated Terminal Pads:** Accommodate terminals for either aluminum or copper conductors.

**Positive Blade Lock and Pryout:** Blade latch prevents switch opening under high momentary current conditions. Easy opening is assured through pryout assist.

**90° Blade Stop:** Furnished with switch. Stops can be field-removed for 180° blade travel.

**Insulators:** Three inch B.C. ANSI® station post. Characteristics are available upon request.

**Steel Channel Base:** Base is rugged, hot dipped galvanized steel channel.

**Vertical Mounting is Standard:** Also available for underhung mounting if specified.

**Special Applications:** Variations to meet specific customer requirements are available upon request.

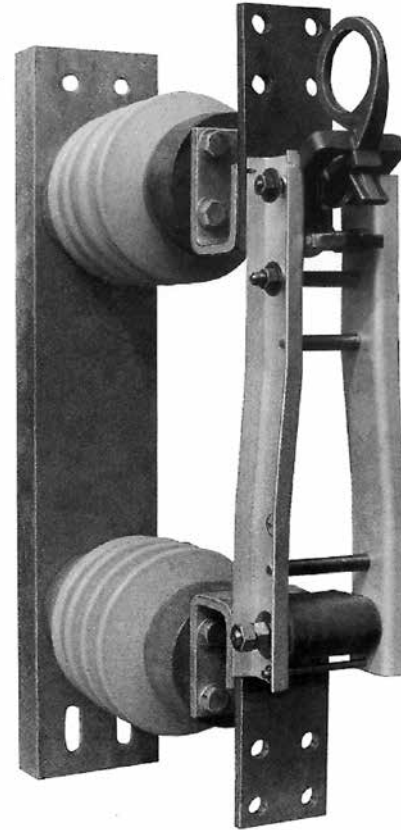

Figure 3. H-72 station-class disconnect switch.

**Table 5. Dimensions and Ordering Information**

Ratings				Catalog Number	3" B.C. Insulator T.R. No.	Dimensions (inches), Reference Only								Approx. Net Wt. lbs.
kV Max.	Cont.	Mom.	BIL			B	C	D	H	J	L	P	T	
15.5	1200	61	110	125931CPS	205	13.63	15	25	10	24	27	16.75	14.88	75
25.8	1200	61	150	125932	208	16.63	18	28	14	27	30	20.75	18.88	100
38.0	1200	61	200	125933CPS	210	22.63	24	34	18	33	36	24.75	22.88	130

Catalog Number Suffix Nomenclature

- B = Backstrap assembly
- I = Inverted construction for overhead use
- L = Loadbuster hook
- P = Parallel groove clamp, bronze
- Y = Cycloaliphatic insulators

Example: 125931PY = 125931 with parallel groove clamps and cycloaliphatic insulators.

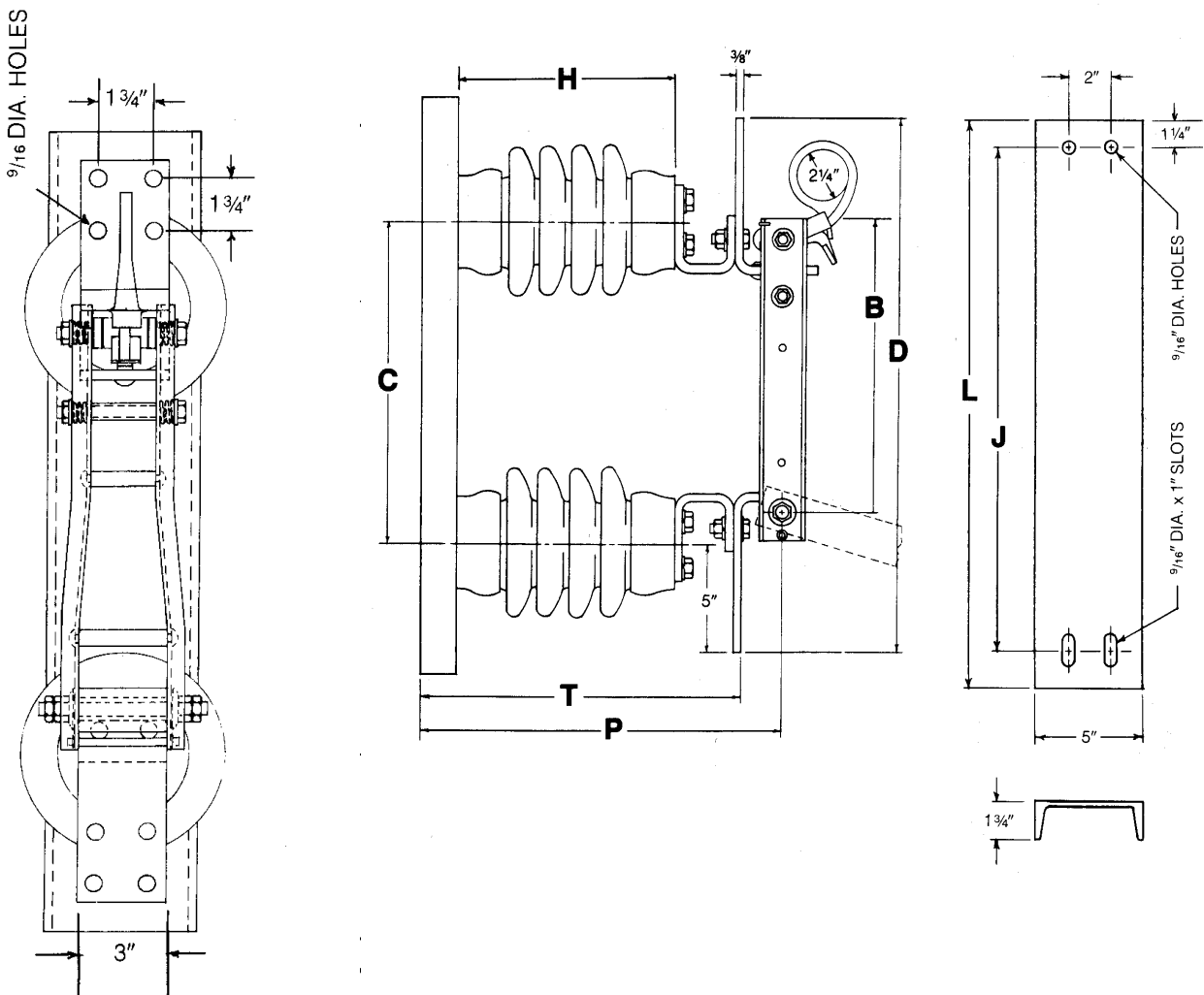

### D73-3P distribution-class oil circuit recloser bypass switch for crossarm and direct pole bracket mounting

**Voltage:**

15.5 kV - 110 kV BIL  
25.8 kV - 125 kV and 150 kV BIL  
38.0 kV - 150 kV BIL

**Current:** 600 A Continuous

**Momentary:** 40 kA Momentary

**Front Contact:** Reduced area, high pressure; hard drawn copper blade to silver-plated hard drawn copper front contact.

**Hinge Contact:** Hard drawn copper blade to silver washer to hard drawn formed copper hinge.

**Tin-Plated Terminal Pads:** Accommodate terminals for either aluminum or copper conductors.

**Terminals:** Not included.

**Versatile Mounting:** Suitable for vertical or underhung mounting and furnished either with a crossarm hanger or a pole mounting bracket.

**Insulators:** 2.25" B.C. with two threaded studs.

**Application:** Economical means of bypassing and disconnecting pole mounted oil circuit reclosers (OCR), permitting maintenance without disturbing continuity of service.

**Features:** The D73-3P switch incorporates all the design features of Eaton's Cooper Power series Kearney D-73 switch into a compact 3-pull bypass unit. It consists of two hookstick disconnect switches mounted on a galvanized channel with a bypass blade connected across the top terminals of each switch.

The bypass blade can be arranged for either right hand or left hand operation.

One mounting channel supports the entire switch for ease of installation and uncluttered appearance. The channel can be either cross arm mounted with a backstrap or bolted directly to a galvanized pole mounting bracket.

A silver washer between the blade and hinge minimizes the possibility of binding and assures ease of blade movement even when the D73-3P switch is installed in areas with high levels of contamination.

All switches have a positive blade lock to prevent opening under high momentary current. Easy opening is assured through pryout assist.

The bypass blade is offset 30° from the plane of the disconnect blades, so that the bypass switch can be operated when the switch is mounted vertically.

**Operation:** The normal position of the 3-pull OCR bypass switch is with the bypass blade open and the two disconnect switches closed. For maintenance, testing, repair or removal of the OCR, first the bypass switch is closed providing a parallel current path to the OCR. After the OCR is opened, both disconnect switches are opened. Thus, service continuity has been maintained and the OCR is isolated from the line.

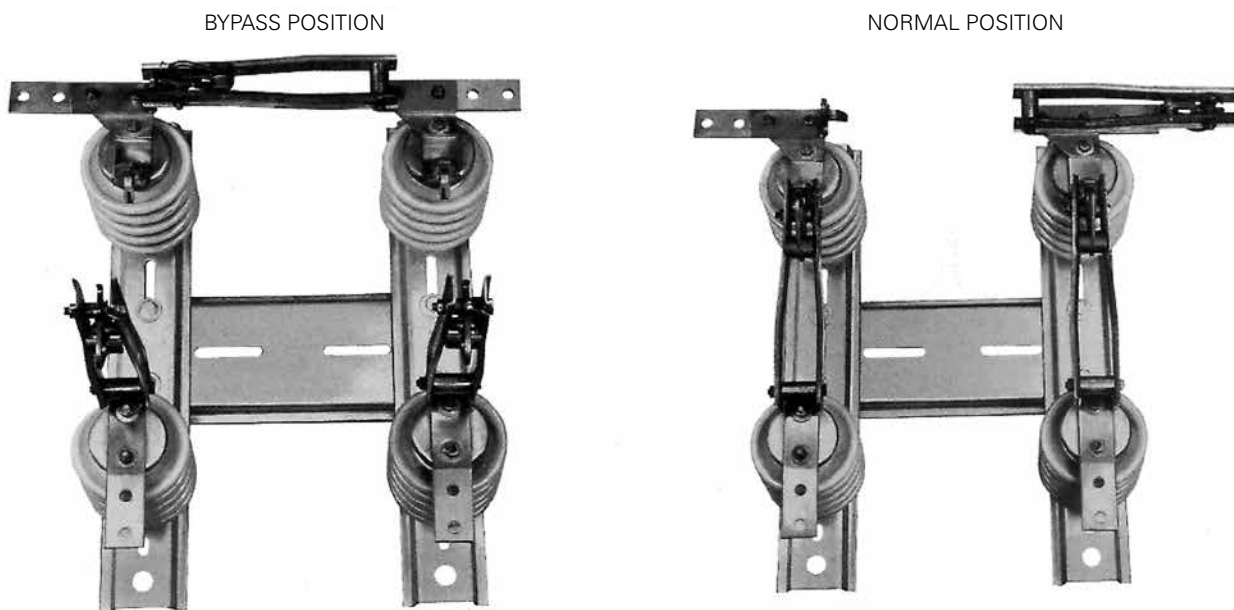

Figure 4. D73-3P 600 A 3-pull oil circuit recloser bypass switch.



Table 6. Dimensions and Ordering Information

Ratings					Dimensions (inches)										Approx Net Wt. (lbs.)	Pole Mount Units
kV Max. Design	BIL kV	Cont. A	Mom. kA	Catalog Number	A	B	C	D	E	F	G	H	I			
15.5	110	600	40	127733_-6_	23.25	30	23.75	6.75	9.13	11.88	15	17.75	12.75	70	85	
25.8	125	600	40	127730_-6_	23.25	30	24	8	9.13	11.88	15	17.75	12.75	78	93	
25.8	150	600	40	127731_-6_	26.25	30	29	10	12.13	14.88	18	20.75	15.75	94	109	
38.0	150	600	40	127732_-6_	26.25	30	29	10	12.13	14.88	18	20.75	15.75	94	109	

**Base Number Suffixes**

- A = 150 degree latch
- C = Captive terminal bolts 1.75" long, stainless steel
- D = Bridge connector holes
- E = Bridge connectors on terminals
- L = Loadbuster hook
- N = No backstrap
- P = Parallel groove clamp, bronze
- Y = Cycloaliphatic insulators

**-6 Suffixes**

- L = Left handed bypass blade operation
- R = Right handed bypass blade operation
- LP = Left handed operation w/pole mounting bracket
- RP = Right handed operation w/pole mounting bracket

Complete Part Number - LP = Live Parts Kit  
Complete Part Number - BXX = Special base

Example 127733L6LP = 127733 w/loadbuster hooks and pole mounting bracket - left handed operation.

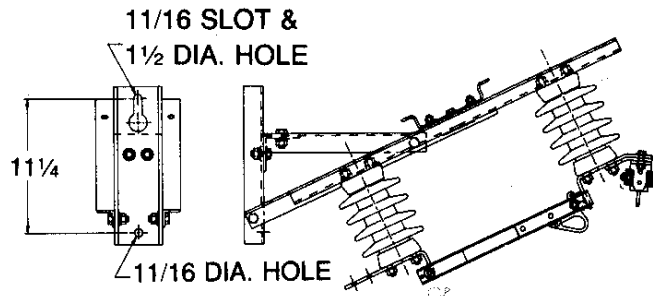
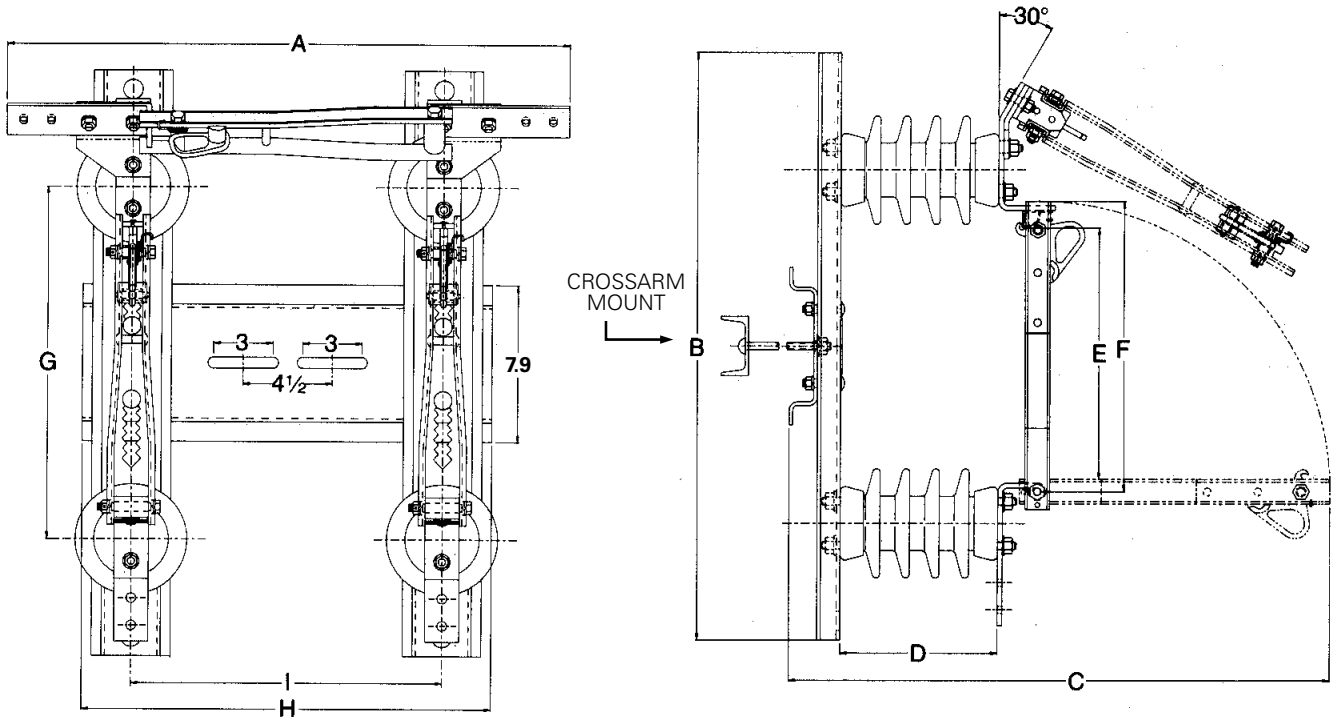

Catalog Number 262400-S6

POLE MOUNT

**M95-3P station-class oil circuit recloser  
bypass switch****Voltage:**

15.5 kV - 110 kV BIL

25.8 kV - 150 kV BIL

38.0 kV - 200 kV BIL

**Current:** 600 A Continuous**Momentary:** 40 kA Momentary**Front Contact:** Reduced area, high pressure; hard drawn copper blade to silver-plated hard drawn copper front contact.**Hinge Contact:** Hard drawn copper blade to silver washer to hard drawn formed copper hinge.**Tin-Plated Terminal Pads:** Accommodate terminals for either aluminum or copper conductors.**Terminals:** Not included.**Versatile Mounting:** Suitable for vertical mounting.**Insulators:** Three inch B.C. ANSI® standard station post.**Application:** Economical means of bypassing and disconnecting oil circuit reclosers (OCR), permitting maintenance without disturbing continuity of service.**Features:** The M95-3P switch incorporates all the design features of Eaton's Cooper Power series Kearney M-72 switch into a compact 3-pull bypass unit. It consists of two hookstick disconnect switches mounted on a galvanized channel with a bypass blade connected across the top terminals of each switch.

The bypass blade can be arranged for either right hand or left hand operation.

One mounting channel supports the entire switch for ease of installation and uncluttered appearance.

A silver washer between the blade and hinge minimizes the possibility of binding and assures ease of blade movement even when the Type M95-3P switch is installed in areas with high levels of contamination.

All switches have a positive blade lock to prevent opening under high momentary current. Easy opening is assured through pryout assist.

The bypass blade is offset 30° from the plane of the disconnect blades, so that the bypass switch can be operated when the switch is mounted vertically.

**Operation:** The normal position of the 3-pull OCR bypass switch is with the bypass blade open and the two disconnect switches closed. For maintenance, testing, repair or removal of the OCR, first the bypass switch is closed providing a parallel current path to the OCR. After the OCR is opened, both disconnect switches are opened. Thus, service continuity has been maintained and the OCR is isolated from the line.

Table 7. Dimensions and Ordering Information

Ratings				Basic Switch Catalog Number	Dimensions (inches), Reference only					Approx. Net Wt. lbs.
kV Max. Design	Cont. A	Mom. kA	BIL kV		A	B	C	D	E	
15.5	600	40	110	127833_-6_	18	12-1/4	10	12	24	135
25.8	600	40	150	127831_-6_	18	12-1/4	14	12	24	180
38.0	600	40	200	127832_-6_	24	18-1/4	18	15	30	230

**Base Number Suffixes**

- A = 150 degree latch
- C = Captive terminal bolts 1.75" long, stainless steel
- D = Bridge connector holes

- E = Bridge connectors on terminals
- L = Loadbuster hook
- N = No backstrap
- P = Parallel groove clamp, bronze
- Y = Cycloaliphatic insulators

**-6 Suffixes**

- L = Left handed bypass blade operation.
- R = Right handed bypass blade operation
- Complete Part Number-LP = Live parts kit
- Complete Part Number-BXX = Special base
- Example 127833L-6P = 127833-6 w/loadbuster hooks and pole mounting bracket - left handed operation.

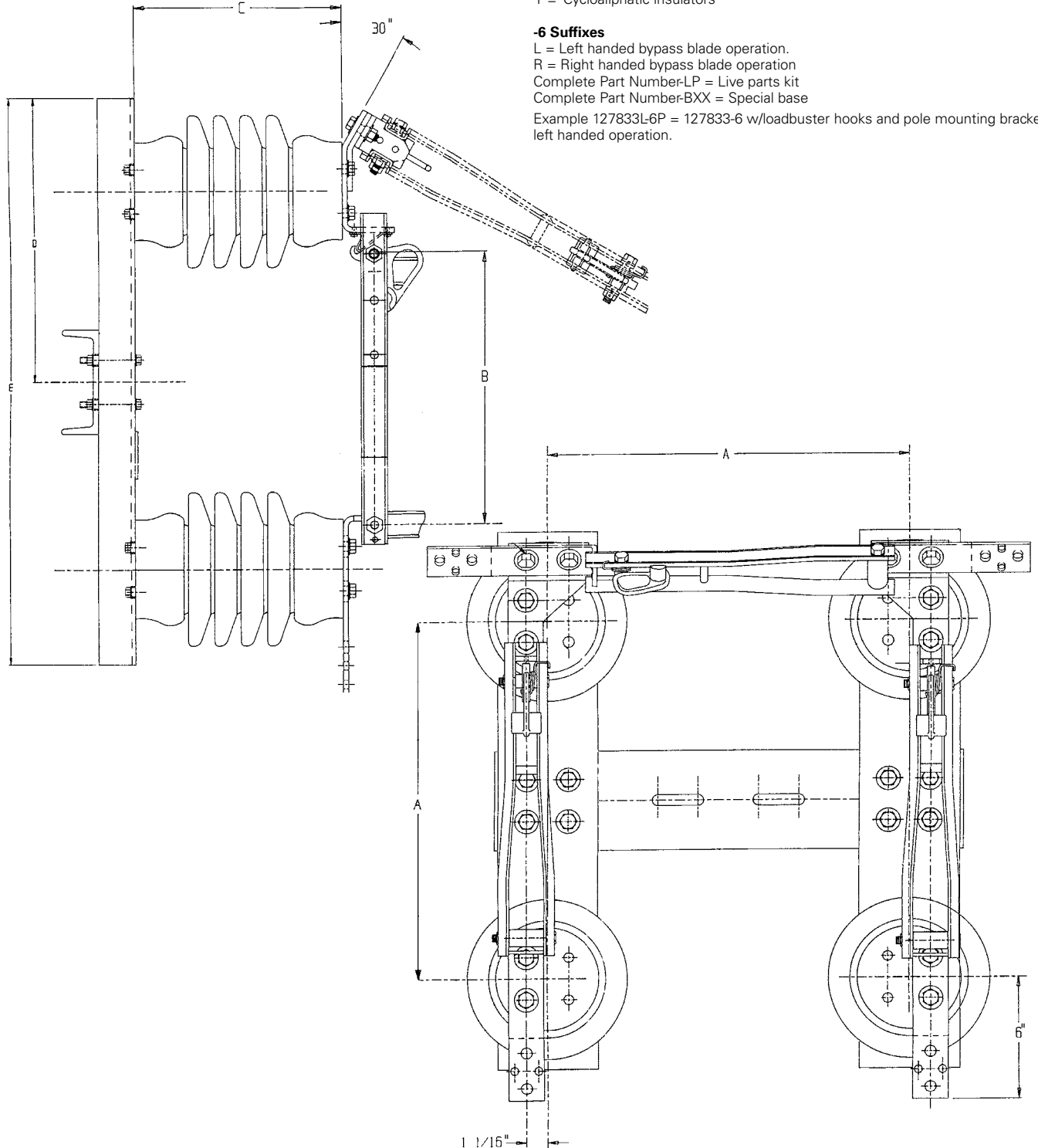

## Oil circuit recloser station-class fused bypass combinations for substation mounting

### Fuse Disconnect Switch

**Voltage:** 15.5 kV and 25.8 kV

**Current:** 100 A or 200 A fuseholder rating, 600 A disconnect switch rating

**Fuse Interrupting Capacity:** 15.5 kV and 25.8 kV, 100 or 200 A fuseholder 7,100 A Symmetrical

**Momentary:** 28 kA momentary on switch

**BIL:** 110 kV and 150 kV BIL

**Insulators:** ANSI® standard station post – 3" B.C.

**Base:** Galvanized structural steel channel

**Terminals:** Two bolt bridge type (#262224) for #4 Sol. to 666.6 MCM ACSR or 0.75" I.P.S. copper are included. Adapters to convert to ANSI® standard two-hole terminal pads available upon request at additional charge.

### Companion Switch

**Voltage:** 15.5 kV and 25.8 kV

**Current:** 600 A continuous

**Momentary:** 40 kA momentary on switch

**BIL:** 110 kV and 150 kV BIL

**Application:** For use when there is a maximum requirement for safety and continuity of service. The fused OCR bypass disconnect combination provides safe isolation of the OCR while maintaining service continuity with a fuse protected circuit.

**Features:** The cutout portion of the combination is a base mounted HX, and will accommodate both 100 A and 200 A fuseholders. The disconnect switches have 600 A continuous rating.

The bypass disconnect combination consists of:

1. A fuse cutout and a single pole disconnect switch mounted in tandem on a common base.
2. A separately mounted single pole companion disconnect switch.

The fuse cutout provides the bypass component of the combination. The disconnect switches provide for isolation of the oil circuit recloser.

**Operation:** With the oil circuit recloser in the closed position (in preparation for maintenance):

1. Place the fuseholder in hinge clip and close the cutout into the bypass position.
2. Open the oil circuit recloser.
3. When both disconnect switches are opened, the oil circuit recloser is isolated and bypassed.

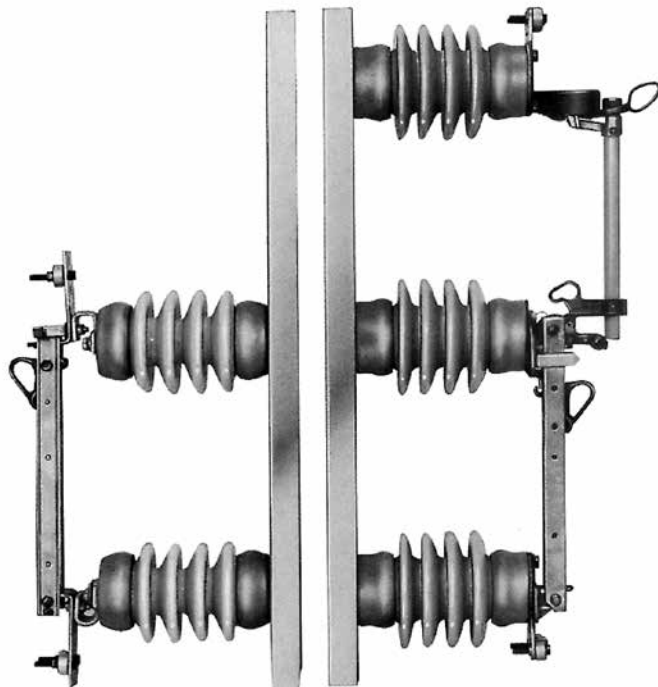

Figure 5. Fused disconnect and companion switch combination.

**Table 8. Fused Disconnect Switch**

Ratings			Catalog Number	Dimensions (inches), Reference Only								Approx Net Wt. lbs.	Fuse Interrupting Capacity-kA	
kV Max. Design	Fuse Cont. A	BIL kV		B	C	D	H	J	L	P	T		Sym.	Asym.
15.5	100	110	125801	16.38	15	38.5	10	37	39.5	13.13	12.13	100	7.1	10.0
	200	110	125802	16.38	15	38.5	10	37	39.5	13.13	12.13	100	7.1	10.0
25.8	100	150	125801-21	19.38	18	44.5	14	43	45.5	17.13	16.13	135	7.1	10.0
	200	150	125802-2	19.38	18	44.5	14	43	45.5	17.13	16.13	135	7.1	10.0

**Table 9. Companion Switch**

Ratings				Catalog Number	Dimensions (inches), Reference Only								Approx. Net Wt. lbs.
kV Max. Design	Fuse Cont. A	BIL kV	B		C	D	H	J	L	M	P	T	
15.5	600	110	125703-5	15.75	15	26	10	37	39.5	17	14.75	13.5	55
25.8	600	150	125728-5	18.75	18	29	14	43	45.5	23	18.75	17.5	78

Catalog Number Suffix Nomenclature  
 Y = Cycloaliphatic insulators  
 I = Inverted insulators  
 A = 2-hole Nema terminal pads

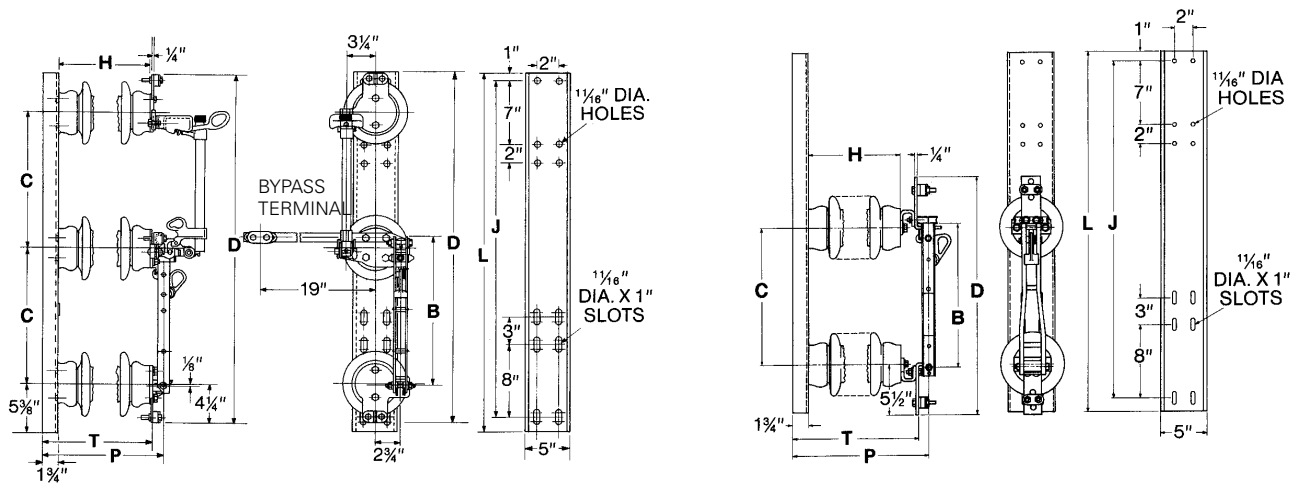

**Figure 6. Fused disconnect switch (left) and companion switch (right).**

**Table 10. Replacement Fuseholders**

Fused Disconnect Catalog No.	kV Fuse	Fuse Cont. A	Replacement Fuseholder Catalog Number
125801	15.5	100	184201-090S6
125802	15.5	200	187201-090S6
125801-21	25.8	100	186303-090S6
125802-2	25.8	200	188303-090S6

**HB-65/HC-65 station-class voltage regulator bypass switch**

**Voltage:** 8.3, 15.5, 25.8 and 38.0 kV

**Current:** 600 A continuous

**Momentary:** 40 kA in closed position, 30 kA in bypass position

**BIL:** 95 kV, 110 kV, 150 kV, and 200 kV BIL

**Jaw Contacts:** Reverse loop-high pressure – silver-plated copper

**Hinge Contacts:** Reduced area – high pressure – silver-plated copper to silver-plated high conductivity bronze.

**Insulators:** ANSI® standard station post – 3" B.C.

**Base:** Galvanized structural steel channel

**Terminal Pads:** ANSI® standard two-hole, tinned to accept copper or aluminum terminals.

**Terminals:** Not included. See page 21.

**Application:** Applicable to all voltage regulators that can be set on neutral for the switching operation. This includes all single-phase and three-phase types, except three-phase induction regulators.

**Operation:** One pull on the pull ring of the 600 A rated switches performs all four switching operations in proper sequence. Opening the bypass disconnect puts it through its four-step automatic switching sequence of bypassing, opening both line leads, and interrupting the exciting current. Enforced sequenced operation minimizes the possibility of operator error.

The 600 A switches, with the exception of the 38.0 kV, are equipped with either the arcruptor or snaphorn. The 38.0 kV switch is available with the snaphorn. The arcruptor has sufficient interrupting capacity for safe interruption of the regulator exciting current with no exposed arcing. While the means for interrupting exciting current is mounted on the right hand blade for mechanical reasons, the common terminal for the series and shunt coils may be connected to either disconnect blade.

**Surge Protection:** Surge protectors are available and provide economical surge protection when mounted across the line terminals of the bypass switches.

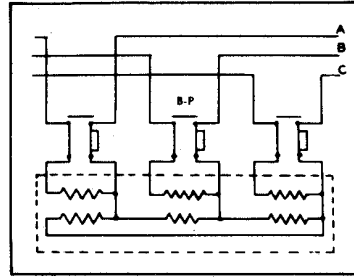

1 three-phase step regulator  
three-phase-delta-3 wire

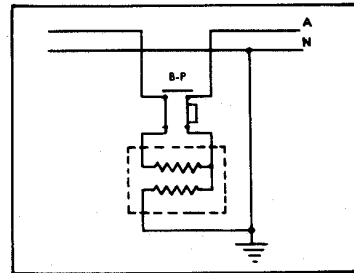

1 single-phase regulator  
single-phase-2 wire

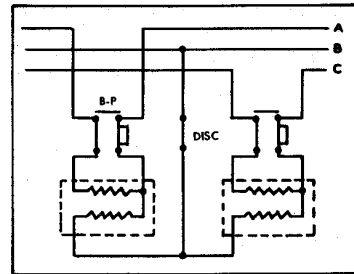

2 single-phase regulators  
three-phase-open delta-3 wire

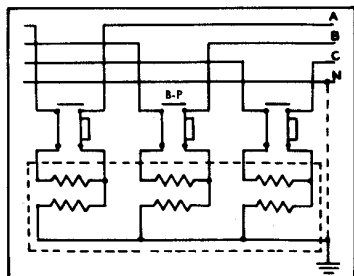

1 three-phase step regulator  
three-phase-wye-3 or 4 wire

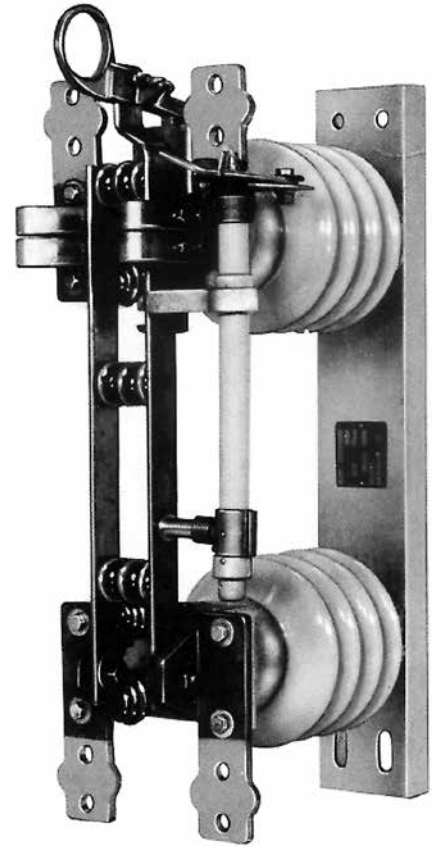

**Figure 7. HB-65 station-class, 600 A voltage regulator bypass switch.**

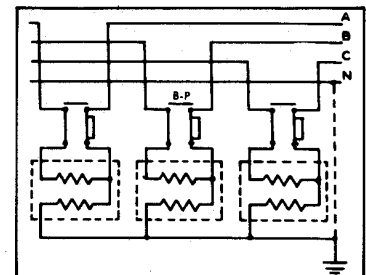

3 single-phase regulators  
three-phase-wye-3 or 4 wire

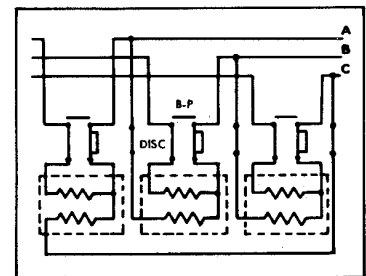

3 single-phase regulators  
three-phase-delta-3 wire

Table 11. Dimensions and Ordering Information

Ratings							Dimensions (inches), Reference Only										Approx. Weight (lbs.)
Catalog Number	Description	Base Type	Max. kV	BIL kV	Cont. Amps	*Mom. kA	A	B	C	D	E	F	G	H	I	J	
125820-20 125830-20	w/Arcruptor w/Snaphorn	HB-65	8.3	95	600	40/30	1.63	19.25	12	23.13	7.5	21	24	13	12.25	4	79
125840 125860	w/Arcruptor w/Snaphorn	HC-65					1.75	19.25	12	23.13	9	22.5	-	13	12.25	-	
125821-20 125831-20	w/Arcruptor w/Snaphorn	HB-65	15.5	110	600	40/30	1.63	22.25	15	26.13	10	24	27	15.5	14.75	4	97
125841 125861	w/Arcruptor w/Snaphorn	HC-65					1.75	22.25	15	26.13	9	25.5	-	15.5	14.75	-	
125822-20 125832-20	w/Arcruptor w/Snaphorn	HB-65	25.8	150	600	40/30	1.63	25.25	18	29.13	14	26.5	29.5	19.5	18.75	4	128
125842 125862	w/Arcruptor w/Snaphorn	HC-65					1.75	25.25	18	29.13	12	28.5	-	19.5	18.75	-	
125853-20	w/Snaphorn	HB-65	38	200	600	40/30	1.75	31.25	24	35.13	18	33	36	23.63	22.88	5	175
125863	w/Snaphorn	HC-65					1.75	31.25	24	35.13	18	34.5	-	23.63	22.88	-	

\* Disconnect Blades/Bypass Blades

Catalog Number Suffix Nomenclature  
 C = Captive terminal bolts 1.75" long, stainless steel  
 D = Bridge connector holes  
 E = Bridge connectors on terminals

I = Inverted insulators for overhead use  
 P = Parallel groove clamp, bronze  
 Y = Cycloaliphatic insulators  
 BASE-LP = Live parts kit  
 BASE-BXX = Special base number

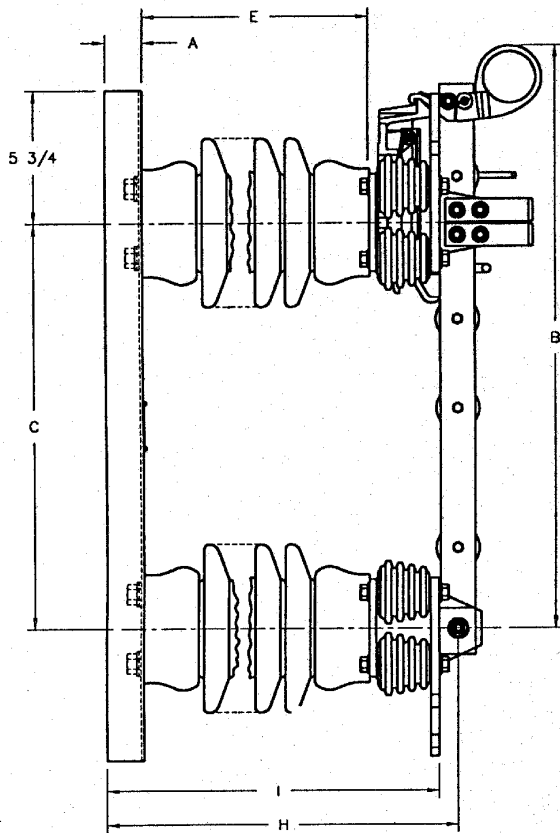

TYPE HB-65 BASE

NOTE: UNIT SHOWN WITH ARCRUPTOR

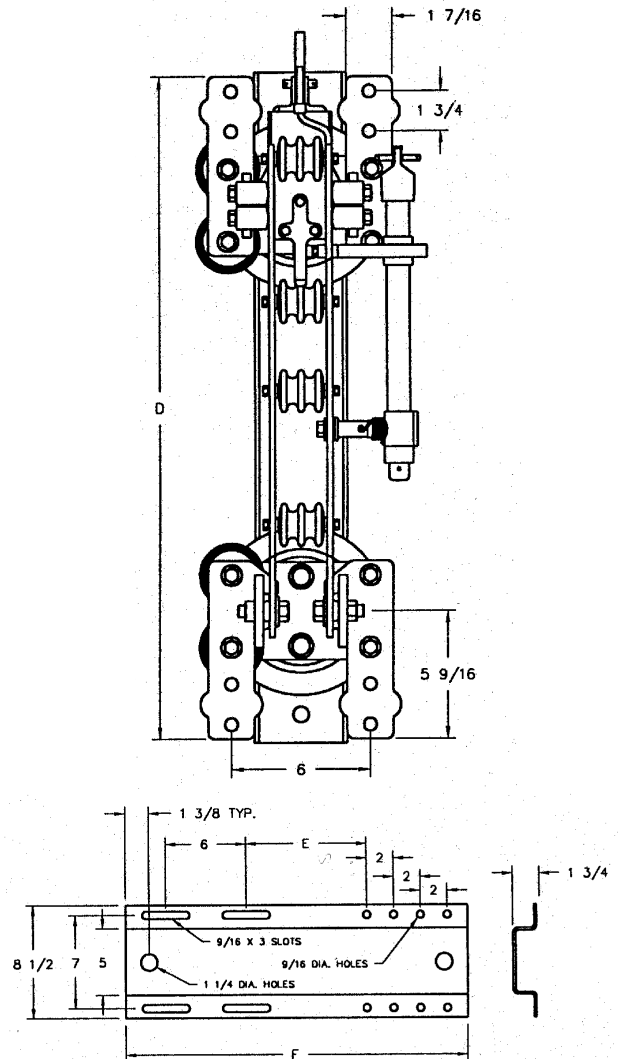

TYPE HC-65 BASE

www.eaton.com/cooperpowerseries

## M-72 station-class bypass switch

Eaton's Cooper Power series Kearney M-72 station-class hookstick operated regulator bypass switches operate efficiently from terminal point to terminal point. Stability of the hard drawn copper channel formed blade construction and associated current carrying components are complemented by switch operating hardware for operating ease, and assurance of dependability under high thermal or momentary conditions.

**Rating:** Current carrying capacity of 600 A continuous and 40 kA momentary.

**Blade Design:** Truss-type construction of formed copper bars has increased width at hinge to assure greater rigidity. This maintains positive alignment during closing and guards against side thrust deflection. Blades are made of hard drawn copper, and are silver-plated at contact points.

**Hard Drawn Copper Contacts:** Uniform conductivity is assured through utilization of hard drawn copper in forming one-piece stationary contacts and terminal pads. Design reduces current interchange points to a minimum.

**Positive Blade Lock and Pryout:** Blade latch prevents opening under high momentary current conditions. Easy opening is assured through pryout assist.

**Silver to Silver Contacts:** Pressure line contacts on clip and circular line contacts on hinge are silver-plated. Silver plating on ends of blade provides silver to silver contact at current transfer points. Contact surfaces are self-cleaning, and self-wiping. Silver washers between blade and hinge act as a bearing to assure easy blade movement after long time exposure to contaminated atmospheres.

**Tin-Plated Terminal Pads:** Accommodates terminals for either aluminum or copper conductors.

**90° Blade Stop:** Furnished with switch. Stops can be field removed for 180° blade travel.

**Insulators:** Three inch B.C. ANSI® standard station post. Cycloaliphatic epoxy insulators also available. Characteristics available upon request.

**Steel Channel Base:** Base is rugged, hot dipped galvanized formed steel.

**Vertical Mounting is Standard:** Available for underhung mounting if specified.

**Terminal Option:** Switches can be furnished with any terminal arrangement documented. Terminals are not included in the price of the switch.

**Special Applications:** Variations to meet specific customer requirements are available upon request.

**Stainless Steel Loadbreak Hooks:** For use with portable load interrupter tool available upon request.

**Application:** Applicable to all voltage regulators that can be set on neutral for the switching operation. This includes all single-phase and three-phase types, except three-phase induction regulators.



**Table 12. Dimensions and Ordering Information**

Catalog Number	Description	Dimension Information (inches)					Nameplate Information		
		A	B	C	D	E	Maximum Voltage kV	Max. Cont. Current Amps	BIL kV
171506-3P	Standard Switch	18	10.25	10	27	30	15.5	600	110
171506-3PA	with Arcruptor	18	10.25	10	27	30	15.5	600	110
171506-3PS	with Snaphorn	18	10.25	10	27	30	15.5	600	110
172506-3P	Standard Switch	24	15.25	14	33	36	25.8	600	150
172506-3PA	with Arcruptor	24	15.25	14	33	36	25.8	600	150
172506-3PS	with Snaphorn	24	15.25	14	33	36	25.8	600	150

Catalog Number Suffix Nomenclature

- C = Captive terminal bolts 1.75" long, stainless steel
- E = Bridge connectors on terminals
- I = Inverted Insulators for overhead use
- P = Parallel groove clamp, bronze
- Y = Cycloaliphatic insulators

Example: 171506CP = 171506 with captive terminal bolts and parallel groove clamps

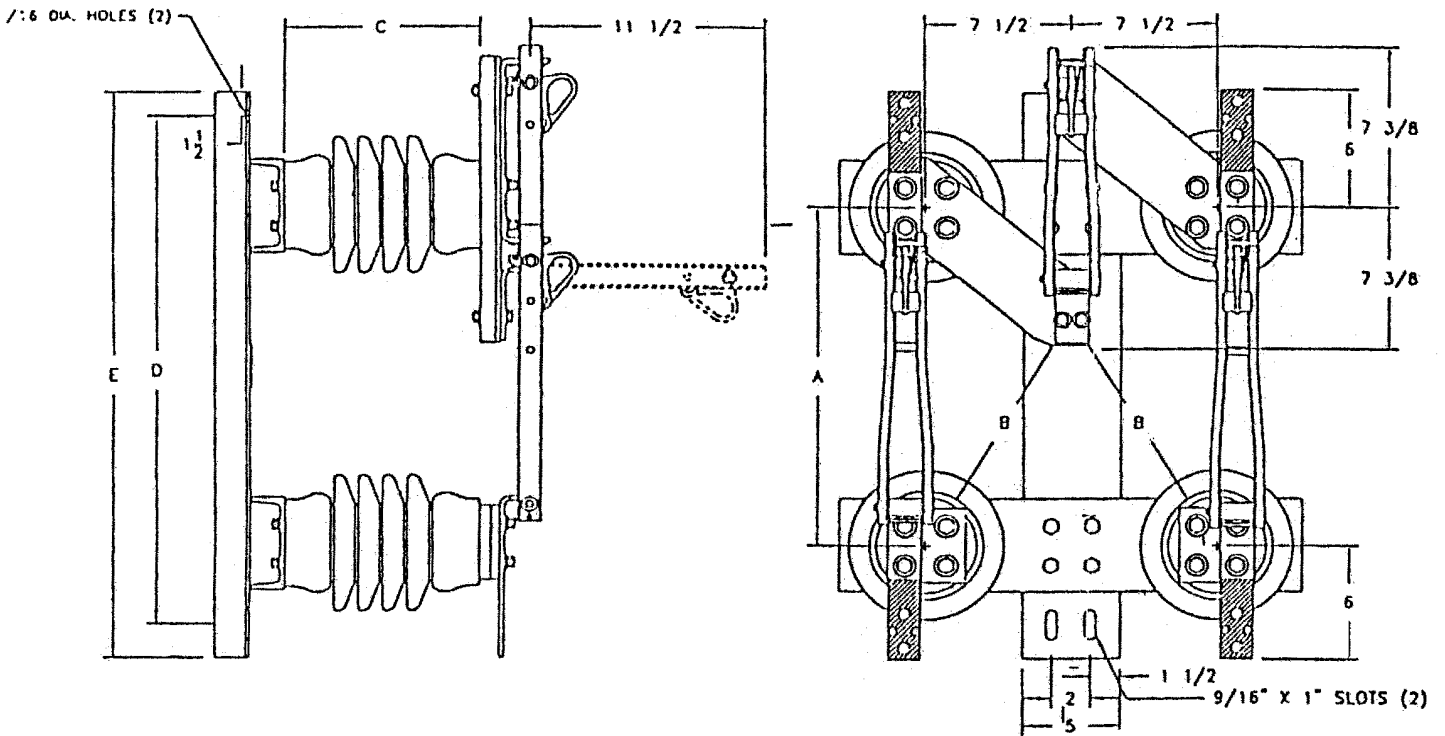

## H72-3P station-class bypass switch

Eaton's Cooper Power series Kearney H72-3P station-class hookstick-operated regulator bypass switches operate efficiently from terminal point to terminal point. Stability of the hard drawn copper channel formed blade construction and associated current carrying components are complemented by switch operating hardware for operating ease, and assurance of dependability under high thermal or momentary conditions.

**Rating:** Current carrying capacity of 1200 A continuous and 61 kA momentary.

**Blade Design:** Truss-type construction of formed copper bars has increased width at hinge to assure greater rigidity. This maintains positive alignment during closing and guards against side thrust deflection. Blades are made of hard drawn copper, and are silver-plated at contact points.

**Hard Drawn Copper Contacts:** Uniform conductivity is assured through utilization of hard drawn copper in forming one-piece stationary contacts and terminal pads. Design reduces current interchange **points to a minimum.**

**Positive Blade Lock and Pryout:** Blade latch prevents opening under high momentary current conditions. Easy opening is assured through pryout assist.

**Silver to Silver Contacts:** Pressure line contact on clip and circular line contact on hinge are silver-plated. Silver plating on ends of blade provides silver to silver contact at current transfer points. Contact surfaces are self-cleaning, and self-wiping. Silver washers between blade and hinge act as a bearing to assure easy blade movement after long time exposure to contaminated atmospheres.

**Tin-Plated Terminal Pads:** Accommodates terminals for either aluminum or copper conductors.

**90° Blade Stop:** Furnished with switch. Stops can be field removed for 180° blade travel.

**Insulators:** Three inch B.C. ANSI® standard station post. Characteristics available upon request.

**Steel Channel Base:** Base is rugged, hot dipped galvanized formed steel.

**Vertical Mounting is Standard:** Available for underhung mounting if specified.

**Terminal Option:** Switches can be furnished with any terminal arrangement documented.

**Special Applications:** Variations to meet specific customer requirements are available upon request.

**Application:** Applicable to all voltage regulators that can be set on neutral for the switching operation. This includes all single-phase and three-phase types, except three-phase induction regulators.

**Table 13. Dimensions and Ordering Information**

Dimension Information (inches)		Nameplate Information							
Catalog Number	Description	A	B	C	D	Max. kV	Cont. A	Mom. kA	BIL kV
171512-3P	Standard switch	30	27	10	18	15.5	1200	61	110
171512-3PA	with Arcruptor	30	27	10	18	15.5	1200	61	110
172512-3P	Standard Switch	36	33	14	24	25.8	1200	61	150
172512-3PA	with Arcruptor	36	33	14	24	25.8	1200	61	150

Catalog Number Suffix Nomenclature  
 C = Captive terminal bolts 1.75" long, stainless steel  
 E = Bridge connectors on terminals  
 I = Inverted insulators for overhead use  
 P = Parallel groove clamp, bronze  
 Y = Cycloaliphatic insulators  
 Base-LP = Live parts kit

Example: 171512CP-3P = 171512-3P with captive terminal bolts and parallel groove clamps

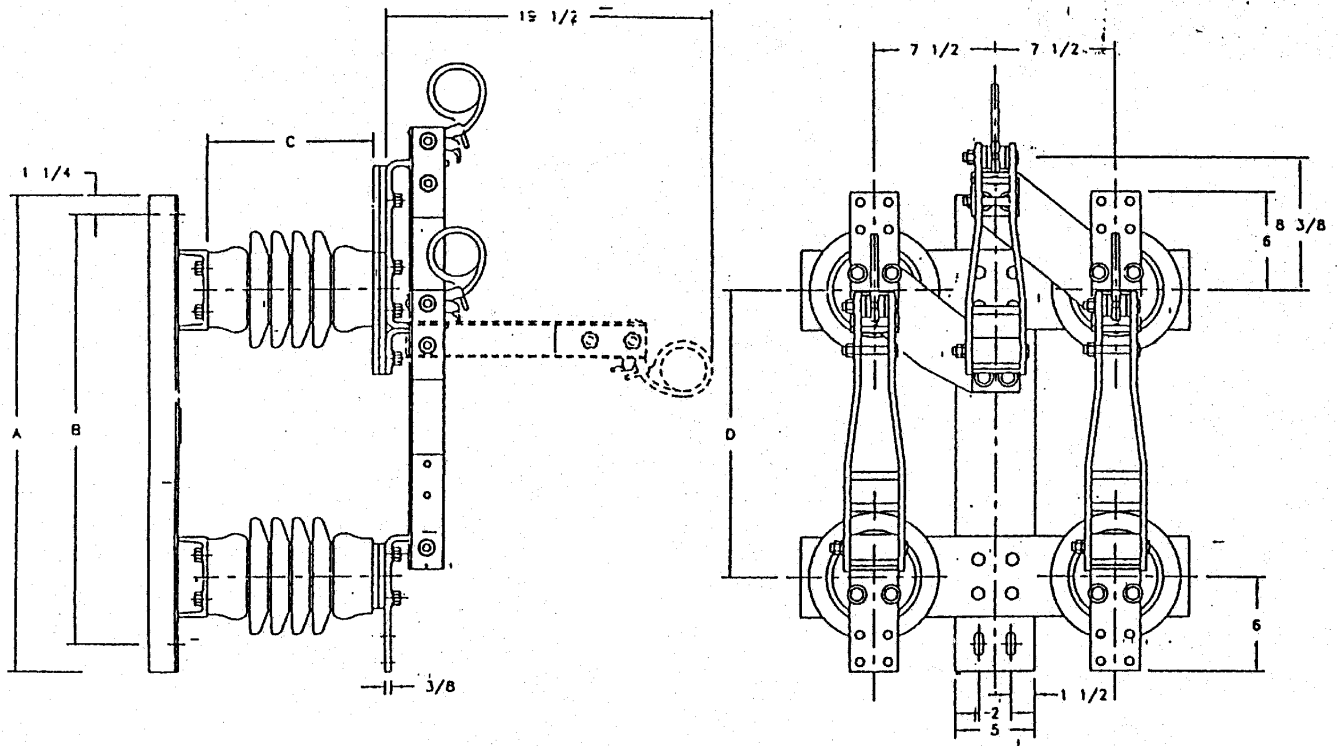

### HB-65 600 A current transformer bypass switch

**Voltage:** 15.5, 25.8, 38.0 and 72.5 kV

**Current:** 600 A continuous

**Momentary:** 40 kA in closed position, 30 kA in bypass position

**BIL:** 95 kV, 110 kV, 200 kV, and 350 kV

**Jaw Contacts:** Reverse loop-high pressure – silver-plated copper

**Hinge Contacts:** Reduced area – high pressure – silver-plated copper to silver-plated high conductivity bronze.

**Insulators:** ANSI® standard station post – 3" B.C.

**Base:** Galvanized structural steel channel

**Terminal Pads:** ANSI® standard two-hole, tinned to accept copper or aluminum terminals.

**Application:** For bypassing and disconnecting current transformers without load dropping and service interruption.

**Operation:** One pull on the 600 A pull ring puts it through its proper and automatic switching sequence of bypassing the current transformer and disconnecting the transformer from service.

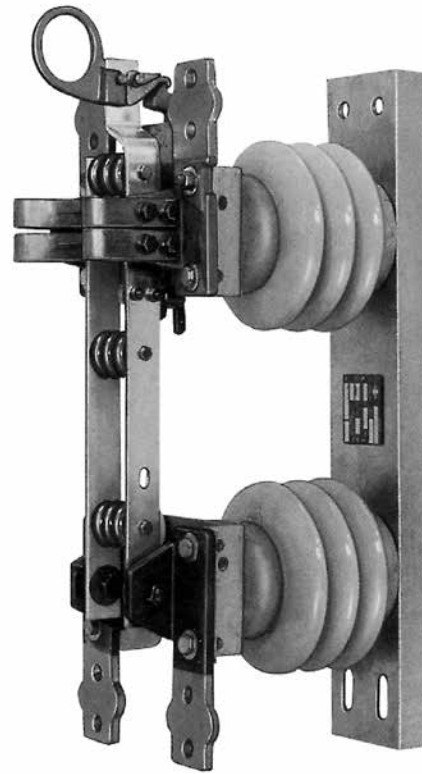
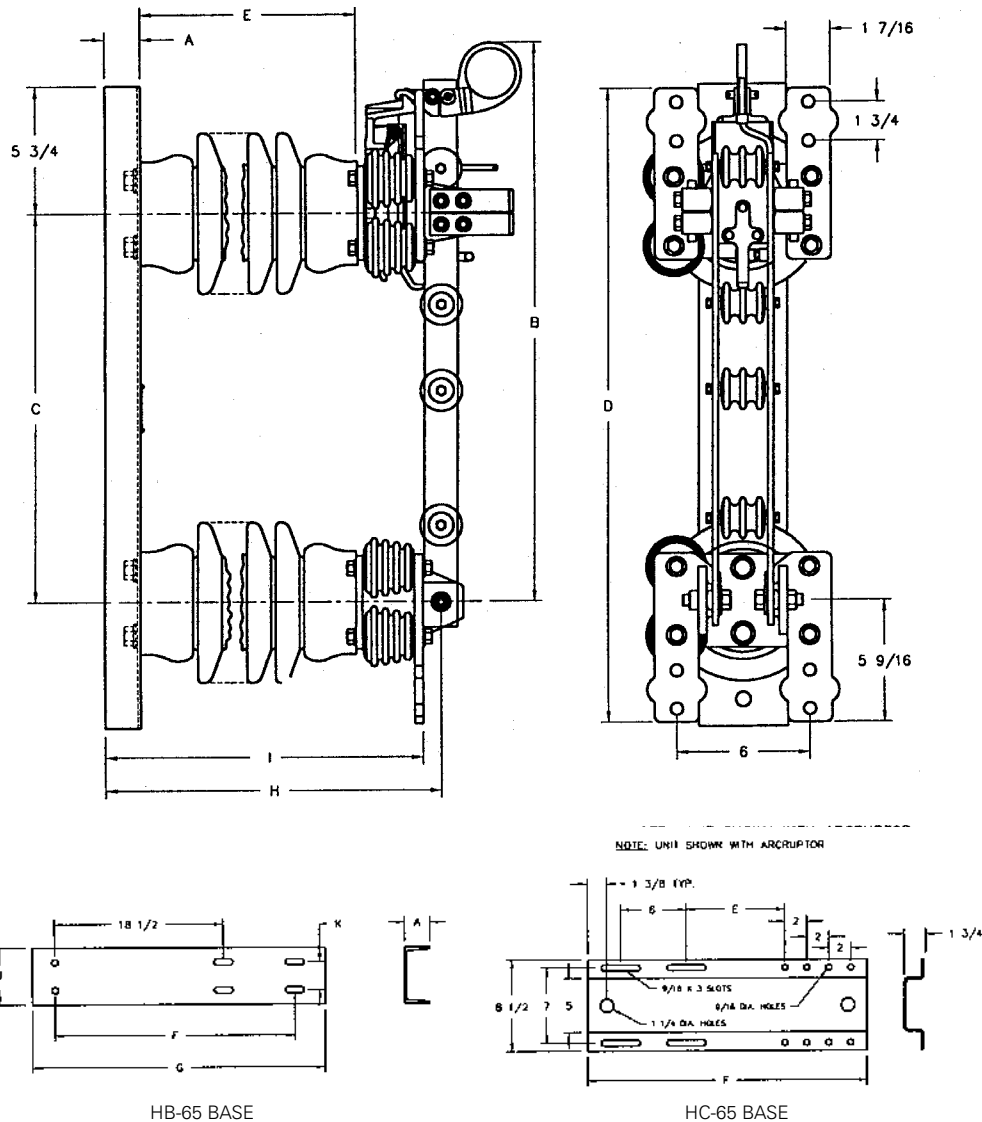

Figure 8. HB-65, 600 A current transformer bypass switch.

Table 14. Dimensions and Ordering Information

Catalog Number	Ratings				Dimensions (inches), Reference only													Approx. Weight (lbs.)
	Type	Max. kV	BIL KV	Cont. A	Mom. kA	A	B	C	D	E	F	G	H	I	J	K		
125824-20	HB-65	15.5	110	600	40	1.63	22.25	15	26.13	10	24	27	15.5	14.75	4	2	95	
125844	HC-65				30	1.75	22.25	15	26.13	10	25.5	-	15.5	14.75	-	-		
125825-20	HB-65	25.8	150	600	40	1.63	25.25	18	29.13	14	26.5	29.5	19.5	18.75	4	2	124	
125845	HC-65				30	1.75	25.25	18	29.13	14	28.5	-	19.5	18.75	-	-		
125826-20	HB-65	38.0	200	600	40	1.75	31.25	24	35.13	18	33	36	23.63	22.88	5	2	173	
125846	HC-65				30	1.75	31.25	24	35.13	18	34.5	-	23.63	22.88	-	-		
125828-20	HB-65	72.5	350	600	40	2.03	49.13	42	53.13	30	51	54	35.63	34.88	6	3	290	

Catalog Number Suffix Nomenclature  
 C = Captive terminal bolts 1.75" long, stainless steel  
 D = Bridge connector holes  
 E = Bridge connectors on terminals  
 I = Inverted insulators for overhead use  
 P = Parallel groove clamp, bronze  
 V = MOV Arrester  
 Y = Cycloaliphatic insulators  
 Base-LP = Live parts kit  
 Base-BXX = Special base number



This page is intentionally left blank.

This page is intentionally left blank.

**Eaton**  
1000 Eaton Boulevard  
Cleveland, OH 44122  
United States  
Eaton.com

**Eaton's Cooper Power Systems Division**  
2300 Badger Drive  
Waukesha, WI 53188  
United States  
Eaton.com/cooperpowerseries

© 2016 Eaton  
All Rights Reserved  
Printed in USA  
Publication No. CA008006EN

Eaton is a registered trademark.  
All other trademarks are property  
of their respective owners.

For Eaton's Cooper Power series product  
information call 1-877-277-4636 or visit:  
[www.eaton.com/cooperpowerseries](http://www.eaton.com/cooperpowerseries).