

Dimensional Drawing

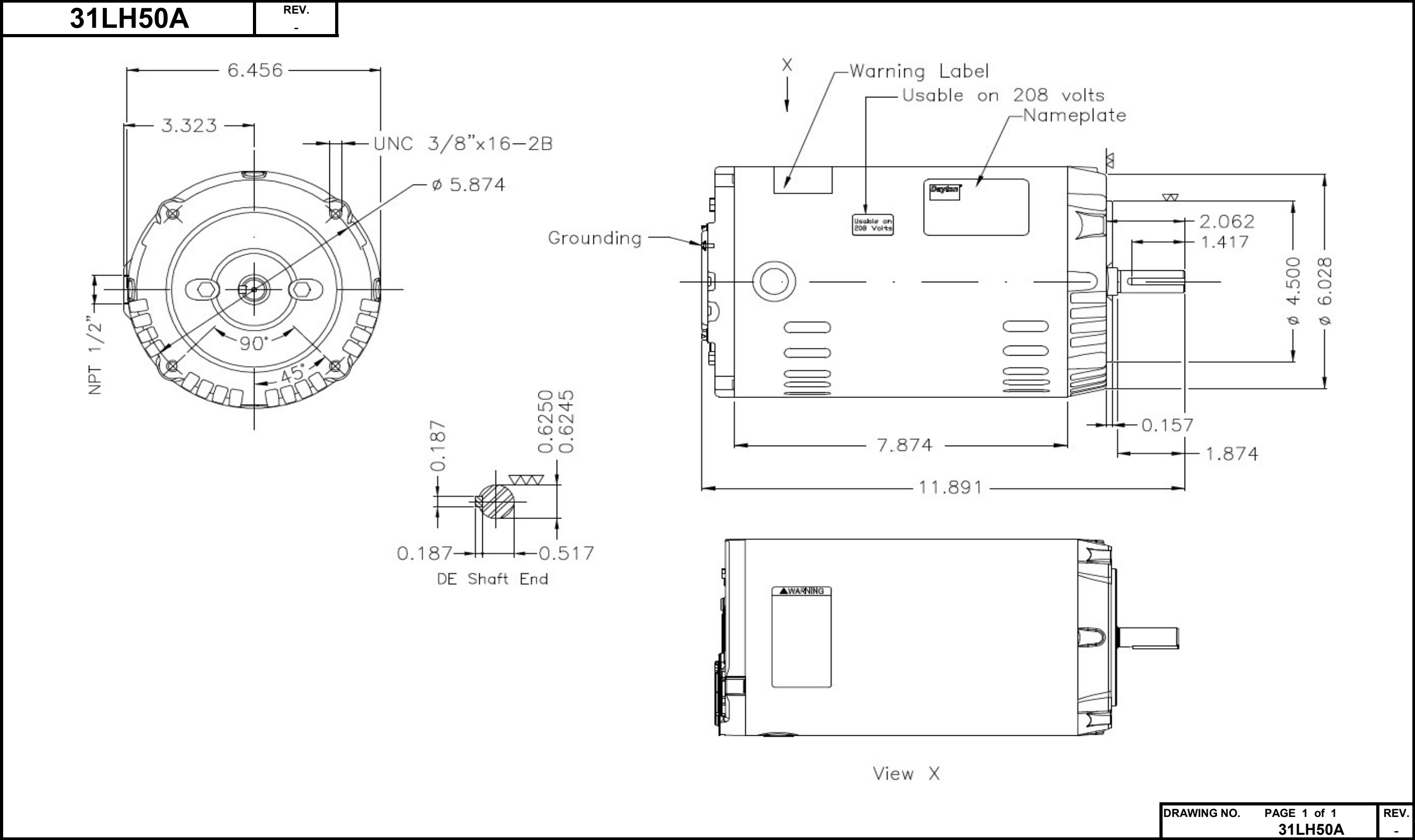

Dayton Electric Mfg. Co. Lake Forest, IL 60045 USA

©2020 W.W. Grainger, Inc. This design may not be reproduced, modified or redistributed without written permission from W.W. Grainger, Inc.

DATA SHEET



Three Phase Induction Motor - Squirrel Cage

Customer

Product line : W01 - ODP - Premium Efficiency

Frame	: 56C	Locked rotor time	: 20 s (hot) 36 s (cold)
Output	: 1.5 HP (1.1 kW)	Temperature rise ⁴	: 80 K
Poles	: 2	Duty cycle	: Cont.(S1)
Frequency	: 60 Hz	Ambient temperature	: -20 °C to +40 °C
Rated voltage	: 230/460 V	Altitude	: 1000 m.a.s.l
Rated current	: 3.70/1.85 A	Cooling method	: IC01 - ODP
L. R. Amperes	: 31.8/15.9 A	Mounting	: F-1
LRC (p.u.)	: 8.6 Code K	Direct of rotation ¹	: Both
No load current	: 1.62/0.809 A	Noise level ²	: 62.0 dB(A)
Rated speed	: 3510 rpm	Starting method	: Direct On Line
Slip	: 2.50 %	Approx. weight ³	: 11.8 kg
Rated torque	: 0.310 kgfm	Design	: B
Locked rotor torque	: 210 %		
Pull up torque	: 175 %		
Breakdown torque	: 330 %		
Insulation class	: F		
Service factor	: 1.15		
Moment of inertia (J)	: 0.0035 kgm ²		

Output	Start	50%	75%	100%	Load type: -
Efficiency (%)	-	81.5	84.0	84.0	Load torque: -
Power factor	0.65	0.73	0.83	0.89	Load inertia (J=GD ² /4): -

	Drive end	Non drive end	Foundation loads
Bearing type	6204-ZZ	6202-ZZ	Maximum traction : 30 kgf
Lubrication interval	-	-	Maximum compression : 42 kgf
Lubricant amount	-	-	
Lubricant type	MOBIL POLYREX EM		

Notes:

* Dayton # 31LH50A

* Connection YY/Y - Document 10003174687

Standards	Specification	: MG1 - Part 10	Vibration	: MG1 - Part 7
	Tests	: MG1 - Part 12	Tolerance	: MG1 - Part 12
	Noise	: MG1 - Part 9		

This revision replaces and cancels the previous one, which must be eliminated.

- (1) When viewed from the drive end.
- (2) Measured at 1m and with tolerance of +3dB(A).
- (3) Approximate weight subject to changes after manufacturing process.
- (4) At the rated point.

These are average values based on tests with sinusoidal power supply, subject to the tolerances stipulated in NEMA MG 1-12.

Rev.	Summary of changes		Performed	Checked	Date
Performed by	mmoctezuma			181274/2016-A	
Checked by	mrsanchez			Page	Revision
Date	21/02/2018			1/2	1

LOAD PERFORMANCE CURVE



Three Phase Induction Motor - Squirrel Cage

Customer

Product line : W01 - ODP - Premium Efficiency

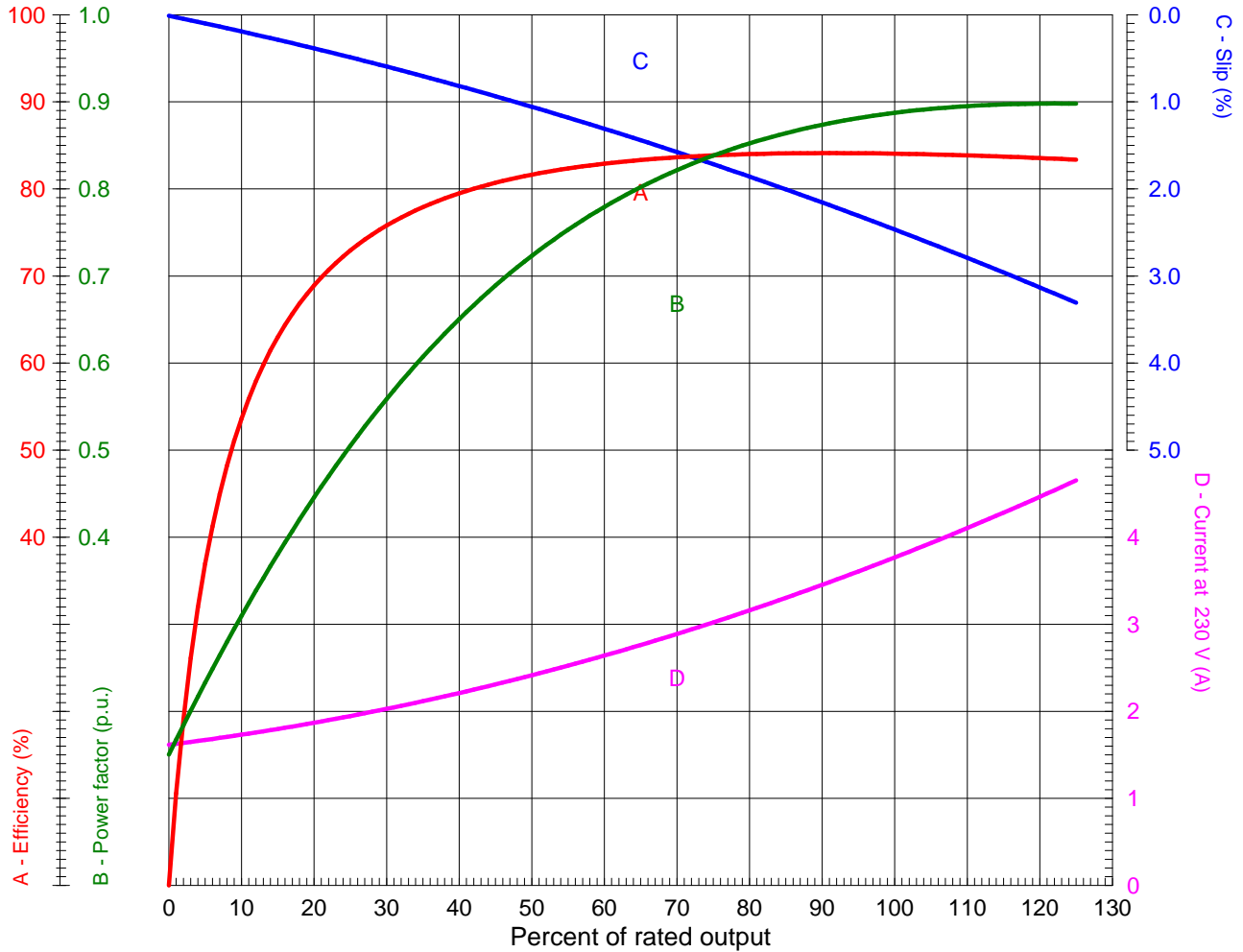

Performance : 1.5 HP (1.1 kW) 230/460 V 60 Hz 2P 56C

Rated current	: 3.70/1.85 A	Moment of inertia (J)	: 0.0035 kgm ²
LRC (p.u.)	: 8.6 Code K	Duty cycle	: Cont.(S1)
Rated torque	: 0.310 kgfm	Insulation class	: F
Locked rotor torque	: 210 %	Service factor	: 1.15
Breakdown torque	: 330 %	Temperature rise	: 80 K
Rated speed	: 3510 rpm	Design	: B

Rev.	Summary of changes		Performed	Checked	Date
Performed by	mmoctezuma			181274/2016-A1	
Checked by	mrsanchez			Page	Revision
Date	21/02/2018			1/1	1

TORQUE AND CURRENT X SPEED CURVE



Three Phase Induction Motor - Squirrel Cage

Customer

Product line : W01 - ODP - Premium Efficiency

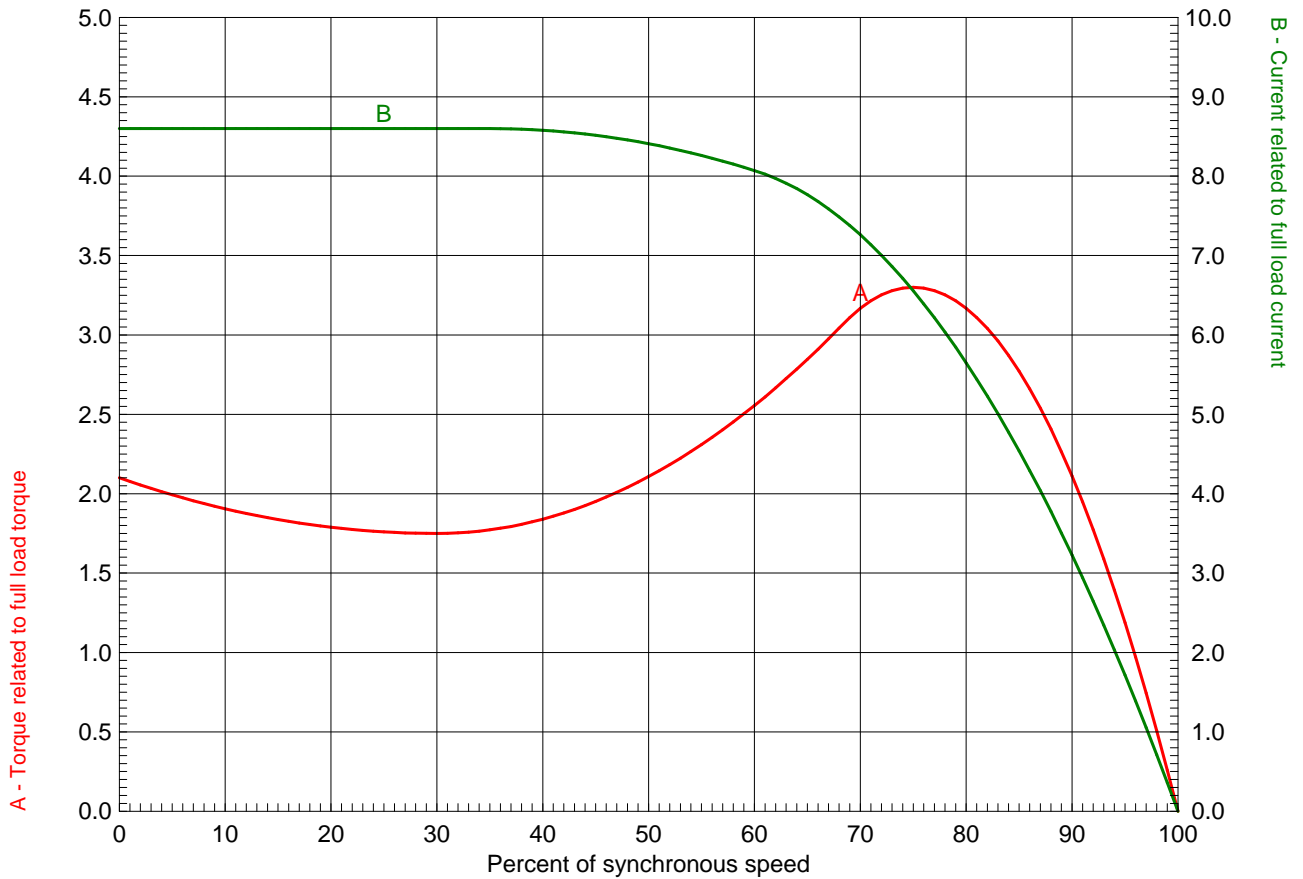

Performance : 1.5 HP (1.1 kW) 230/460 V 60 Hz 2P 56C

Rated current : 3.70/1.85 A	Moment of inertia (J) : 0.0035 kgm ²
LRC (p.u.) : 8.6 Code K	Duty cycle : Cont.(S1)
Rated torque : 0.310 kgfm	Insulation class : F
Locked rotor torque : 210 %	Service factor : 1.15
Breakdown torque : 330 %	Temperature rise : 80 K
Rated speed : 3510 rpm	Design : B

Locked rotor time 100% : 20 s (hot) 36 s (cold)
 Load inertia (J=GD²/4) : 0.0035 kgm²

Rev.	Summary of changes	Performed	Checked	Date
Performed by	mmoctezuma	181274/2016-A1		
Checked by	mrsanchez	Page	Revision	
Date	21/02/2018	1/1	1	

Wiring Diagram



31LH50A

REV.
0

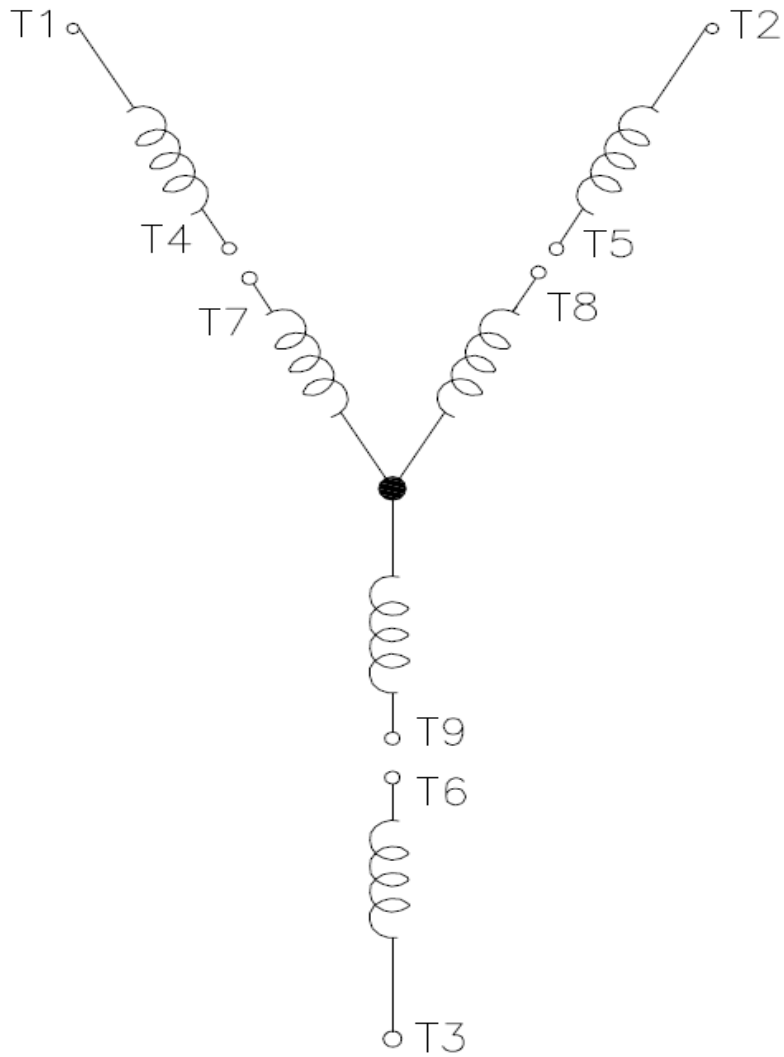

High Voltage (Y)

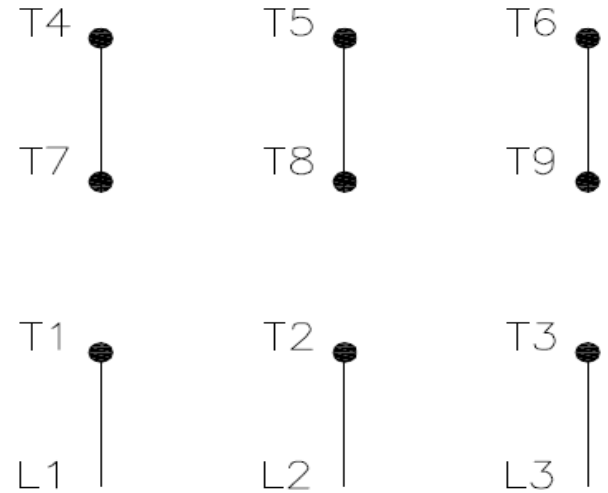

Low Voltage (YY)

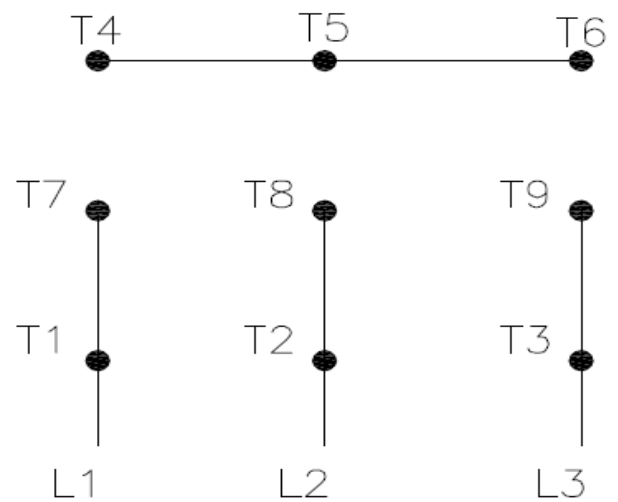

- T1 — Blue
- T2 — White
- T3 — Orange
- T4 — Yellow
- T5 — Black
- T6 — Gray
- T7 — Pink
- T8 — Red
- T9 — Brick Red

Interchange any two line wires to reverse rotation.

DRAWING NO.	PAGE 1 of 1	REV.
31LH50A		0

20MAR18

Dayton®

MADE IN MEXICO

NEMA
Premium®MODEL NO. **C****UL**® US**CE****CSA**®
C US
Energy Verified**31LH50A**

TO0IC0X0X0000100646

MAT: 13827607

PH 3	HP (kW) 1.5(1.1)
HZ 60	V 230/460
RPM 3510	A 3.70/1.85
FR 56C	DES B
IP 21	ENCL ODP
AMB 40 °C	CODE K
SF 1.15	INS F ΔT 80 K
SFA 4.2/2.1 A	PF 0.89
DUTY CONT	
AVG F.L. EFF.	84.0%

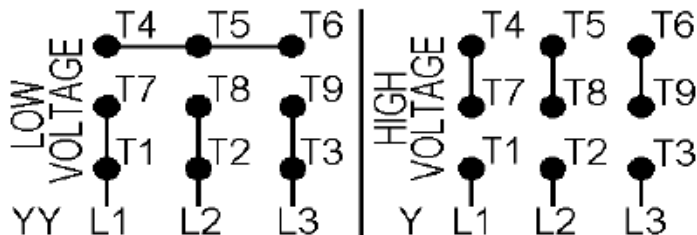

T1-BLU T2-WHT T3-ORG T4-YEL T5-BLK
T6-GRY T7-PNK T8-RED T9-BRK RED

INTERCHANGE ANY TWO LINE WIRES TO REVERSE ROTATION

ALT. RATING: 190-220/380-415V 50Hz
1.5HP 4.42-3.94/2.21-2.09 A 2890 RPM S.F. 1.15

S/N:

Mfd. for Dayton Electric Mfg. Co., Lake Forest, IL 60045 USA