



Customer information packet

EM3554T-8

1.5HP, 1770RPM, 3PH, 60HZ, 145T, 3524M, TEFC, F

Class - None

Division - Not Applicable

Specifications

Enclosure	TEFC
Frame	145T
Frame Material	Steel
Frequency	60.00 Hz
Motor Letter Type	Three Phase
Output @ Frequency	1.500 HP @ 60 HZ
Phase	3
Synchronous Speed @ Frequency	1800 RPM @ 60 HZ
Voltage @ Frequency	200.0 V @ 60 HZ
XP Class and Group	None
XP Division	Not Applicable
Agency Approvals	CSA EEV UR NEMA_PREMIUM NEMA PREMIUM
Ambient Temperature	40 °C
Auxillary Box	No Auxillary Box
Auxillary Box Lead Termination	None
Base Indicator	Rigid
Bearing Grease Type	Polyrex EM (-20F +300F)
Blower	None
Current @ Voltage	5.060 A @ 208.0 V 4.900 A @ 200.0 V
Design Code	B
Drip Cover	No Drip Cover
Duty Rating	CONT
Efficiency @ 100% Load	86.5 %
Electrically Isolated Bearing	Not Electrically Isolated
Feedback Device	NO FEEDBACK
Front Shaft Indicator	None
Heater Indicator	No Heater
High Voltage Full Load Amps	4.9 a

Part detail

Revision	A
Type	AC
Mech. spec.	35AA001
Base	
Status	PRD/A
Elec. spec.	35WGG121
Layout	35LYAA001
Eff. date	03-28-2023
CD Diagram	CD0006
Poles	04
Leads	3#18
Proprietary	False
Created date	03-11-2022

Insulation Class	F
Inverter Code	Inverter Ready
KVA Code	M
Lifting Lugs	No Lifting Lugs
Locked Bearing Indicator	No Locked Bearing
Motor Lead Quantity/Wire Size	3 @ 18 AWG
Motor Lead Termination	Flying Leads
Motor Standards	NEMA
Motor Type	3524M
Mounting Arrangement	F1
Number of Poles	4
Overall Length	13.31 IN
Power Factor	75
Product Family	General Purpose
Pulley End Bearing Type	Ball
Pulley Face Code	Standard
Pulley Shaft Indicator	Standard
Rodent Screen	None
Service Factor	1.15
Shaft Diameter	0.875 IN
Shaft Ground Indicator	No Shaft Grounding
Shaft Rotation	Reversible
Shaft Slinger Indicator	No Slinger
Speed	1770 rpm
Speed Code	Single Speed
Starting Method	Direct on line
Thermal Device - Bearing	None
Thermal Device - Winding	None
Vibration Sensor Indicator	No Vibration Sensor
Winding Thermal 1	None
Winding Thermal 2	None

Nameplate

NP3441L									
CAT.NO.									
SPEC.	35AA001G121G1								
HP	1.5								
VOLTS	200								
AMP	4.9								
RPM	1770								
FRAME	145T		HZ	60		PH	3		
SER.F.	1.15	CODE	M	DES	B	CL	F		
NEMA-NOM-EFF	86.5	PF	75						
RATING	40C AMB-CONT								
CC	010A		USABLE AT 208V				N/A		
DE	6205		ODE	6203					
ENCL	TEFC	SN							
VPWM INVERTER READY									
CT6-60H(10:1)VT3-60H(20:1									
	SFA 5.45								

Accessories

Part number	Description	Multiplier
35-8762	C FACE KIT	A8
35EP1506A01SP	D-FLANGE KIT	A8

AC Induction Motor Performance Data

Record # 82046

Typical performance - not guaranteed values

Winding: 35WGG121-R001		Type: 3522M		Enclosure: TEFC	
Nameplate Data			200 V, 60 Hz: Single Voltage Motor		
Rated Output (HP)	1.5	Full Load Torque	4.51 LB-FT		
Volts	200	Start Configuration	direct on line		
Full Load Amps	4.8	Breakdown Torque	18.41 LB-FT		
R.P.M.	1768	Pull-up Torque	9.82 LB-FT		
Hz	60 Phase	3	Locked-rotor Torque	12.07 LB-FT	
NEMA Design Code	B	KVA Code	L	Starting Current	44.32 A
Service Factor (S.F.)	1	No-load Current	2.61 A		
NEMA Nom. Eff.	86.5	Power Factor	77	Line-line Res. @ 25°C	2.76 Ω
Rating - Duty	40C AMB-CONT		Temp. Rise @ Rated Load	41°C	
			Locked-rotor Power Factor	60.3	
			Rotor inertia	0.159 lb-ft ²	

Load Characteristics 200 V, 60 Hz, 1.5 HP

% of Rated Load	25	50	75	100	125	150
Power Factor	38	59	72	79	83	85
Efficiency	78	85.3	86.8	86.4	85	83.3
Speed	1791	1783	1773	1764	1753	1741
Line amperes	2.79	3.27	3.93	4.77	5.76	6.83

ABB Motors and Mechanical Inc.

WINDING # 35WGG121

Typical performance - not guaranteed values.

1.5 HP 3 PH 60 HZ 1768 RPM 200 V 3522M

TORQUES (LB-FT): PO=18.41 PU=9.82 LR=12.07 LRA=44.32

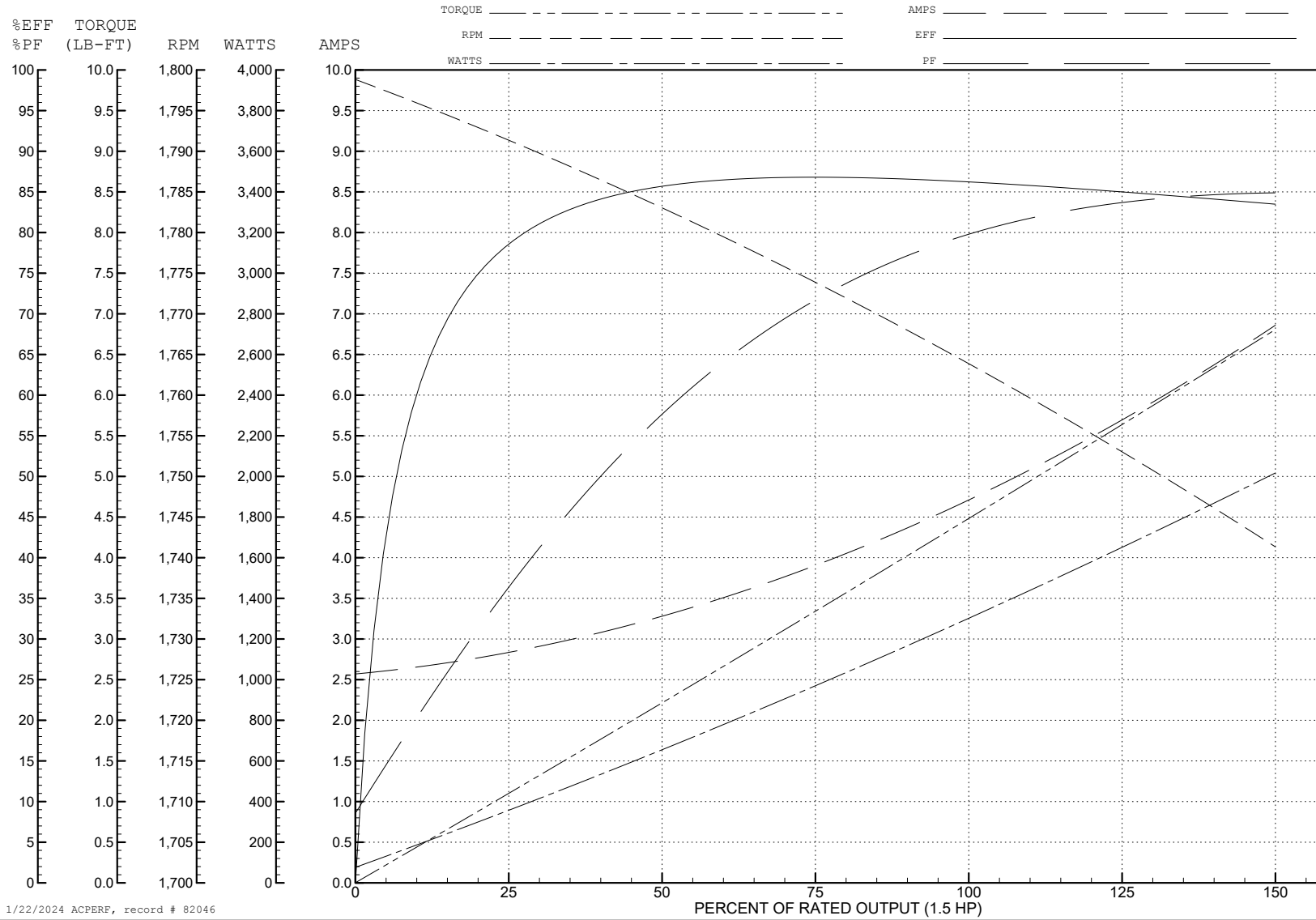

1/22/2024 ACPERF, record # 82046

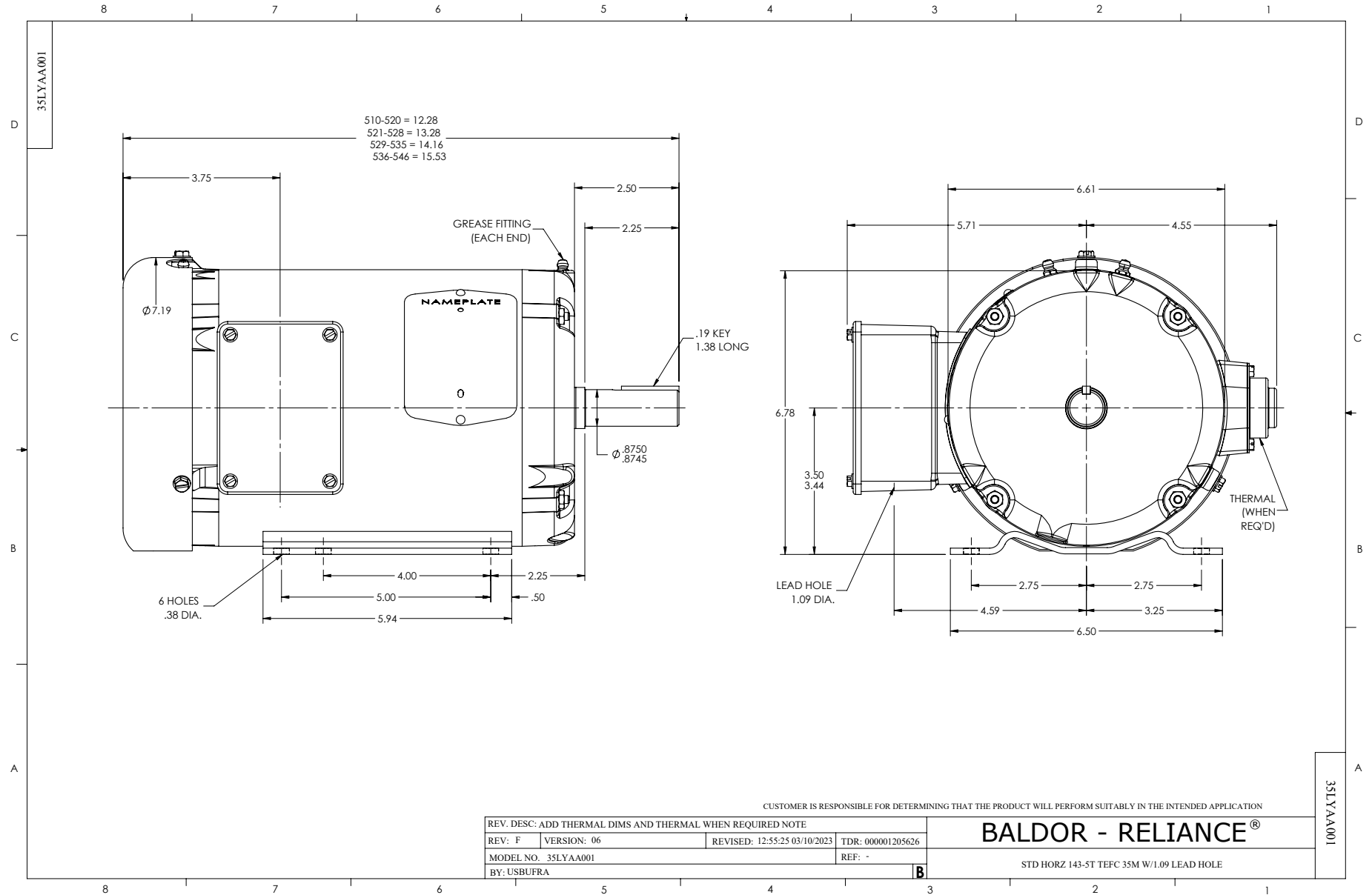

CD0006

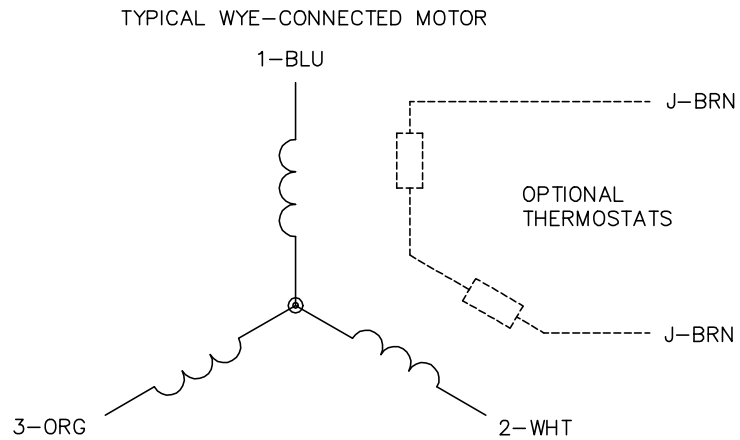

NOTES:

1. THREE LEAD MOTOR MAY BE EITHER WYE CONNECTED OR DELTA CONNECTED.
2. INTERCHANGE ANY TWO LINE LEADS TO REVERSE ROTATION.
3. OPTIONAL THERMOSTATS ARE PROVIDED WHEN SPECIFIED.
4. ACTUAL NUMBER OF INTERNAL PARALLEL CIRCUITS MAY VARY.
5. LEAD COLORS ARE OPTIONAL. LEADS MUST BE NUMBERED AS SHOWN.

CD0006

REV. DESC: ADD CLASS CONN00000007		
REV. LTR: E	VERSION: 01	TDR: 000001099922
FILE: \AAA\00005\141	REVISED: 10:24:49 02/19/2019	BY: ENBRIRO
MTL: -	© □	

BALDOR - RELIANCE®

3PH, SV, 3 LEADS, WYE OR DELTA CONNECTED

SH 1 of 1