



Customer information packet

EM3545-5

1HP, 3450RPM, 3PH, 60HZ, 56, 3516M, TEFC, F1, N

Class - None

Division - Not Applicable

Specifications

Enclosure	TEFC
Frame	56
Frame Material	Steel
Frequency	60.00 Hz
Motor Letter Type	Three Phase
Output @ Frequency	1.000 HP @ 60 HZ
Phase	3
Synchronous Speed @ Frequency	3600 RPM @ 60 HZ
Voltage @ Frequency	575.0 V @ 60 HZ
XP Class and Group	None
XP Division	Not Applicable
Agency Approvals	CSA EEV NEMA PREMIUM NEMA_PREMIUM UR
Ambient Temperature	40 °C
Auxillary Box	No Auxillary Box
Auxillary Box Lead Termination	None
Base Indicator	Rigid
Bearing Grease Type	Polyrex EM (-20F +300F)
Blower	None
Current @ Voltage	1.100 A @ 575.0 V
Design Code	B
Drip Cover	No Drip Cover
Duty Rating	CONT
Efficiency @ 100% Load	77.0 %
Electrically Isolated Bearing	Not Electrically Isolated
Feedback Device	NO FEEDBACK
Front Face Code	Standard
Front Shaft Indicator	None
Heater Indicator	No Heater
High Voltage Full Load Amps	1.1 a

Part detail

Revision	E
Type	AC
Mech. spec.	35T696
Base	
Status	PRD/A
Elec. spec.	35WGL509
Layout	35LYT696
Eff. date	08-19-2022
CD Diagram	CD0006
Poles	02
Leads	3#18
Proprietary	False
Created date	03-01-2016

Insulation Class	B
Inverter Code	Inverter Ready
KVA Code	K
Lifting Lugs	No Lifting Lugs
Locked Bearing Indicator	No Locked Bearing
Motor Lead Exit	Ko Box
Motor Lead Quantity/Wire Size	3 @ 18 AWG
Motor Lead Termination	Flying Leads
Motor Standards	NEMA
Motor Type	3516M
Mounting Arrangement	F1
Number of Poles	2
Overall Length	12.23 IN
Power Factor	85
Product Family	General Purpose
Pulley End Bearing Type	Ball
Pulley Face Code	Standard
Pulley Shaft Indicator	Standard
Rodent Screen	None
RoHS Status	ROHS COMPLIANT
Service Factor	1.25
Shaft Diameter	0.625 IN
Shaft Extension Location	Pulley End
Shaft Ground Indicator	No Shaft Grounding
Shaft Rotation	Reversible
Shaft Slinger Indicator	No Slinger
Speed	3450 rpm
Speed Code	Single Speed
Starting Method	Direct on line
Thermal Device - Bearing	None
Thermal Device - Winding	None
Vibration Sensor Indicator	No Vibration Sensor
Winding Thermal 1	None
Winding Thermal 2	None

Nameplate

NP3441L									
CAT.NO.	EM3545-5								
SPEC.	35T696L509G1								
HP	1								
VOLTS	575								
AMP	1.1								
RPM	3450								
FRAME	56		HZ	60		PH	3		
SER.F.	1.25	CODE	K	DES	B	CL	B		
NEMA-NOM-EFF	77	PF	85						
RATING	40C AMB-CONT								
CC	010A		USABLE AT 208V				N/A		
DE	6205	ODE	6203						
ENCL	TEFC	SN							
VPWM INVERTER READY									
CT6-60H(10:1)VT3-60H(20:1									
	SFA 1.3								

AC Induction Motor Performance Data

Record # 55694

Typical performance - not guaranteed values

Winding: 35WGL509-R001		Type: 3516M	Enclosure: TEFC	
Nameplate Data			575 V, 60 Hz: Single Voltage Motor	
Rated Output (HP)	1	Full Load Torque	1.47 LB-FT	
Volts	575	Start Configuration	direct on line	
Full Load Amps	1.1	Breakdown Torque	6.14 LB-FT	
R.P.M.	3450	Pull-up Torque	2.83 LB-FT	
Hz	60 Phase	3	Locked-rotor Torque	5.1 LB-FT
NEMA Design Code	B KVA Code	K	Starting Current	8.83 A
Service Factor (S.F.)		1.25	No-load Current	0.471 A
NEMA Nom. Eff.	77 Power Factor	85	Line-line Res. @ 25°C	24.3 Ω
Rating - Duty	40C AMB-CONT		Temp. Rise @ Rated Load	38°C
S.F. Amps		1.3	Temp. Rise @ S.F. Load	47°C
			Locked-rotor Power Factor	59.6
			Rotor inertia	0.0443 LB-FT ²

Load Characteristics 575 V, 60 Hz, 1 HP

% of Rated Load	25	50	75	100	125	150	S.F.
Power Factor	54	71	81	85	89	90	89
Efficiency	57.9	71.2	76.3	78.1	78.5	77.2	78.5
Speed	3564	3534	3501	3462	3423	3374	3423
Line amperes	0.547	0.682	0.862	1.09	1.31	1.58	1.31

ABB Motors and Mechanical Inc.

WINDING # 35WGL509

Typical performance - not guaranteed values.

1 HP 3 PH 60 HZ 3450 RPM 575 V 3516M

TORQUES (LB-FT): PO=6.14 PU=2.83 LR=5.1 LRA=8.83

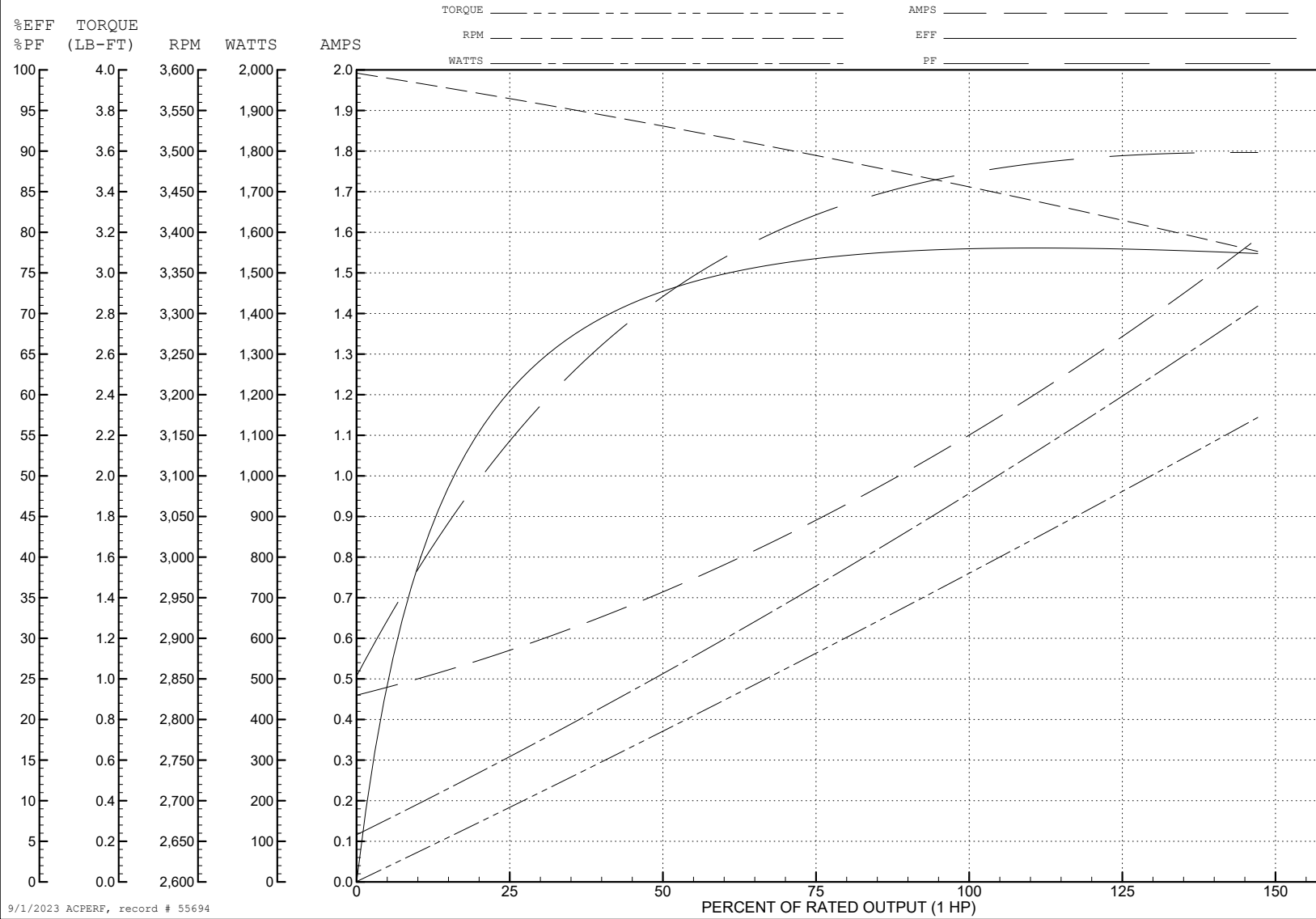

9/1/2023 ACPERF, record # 55694

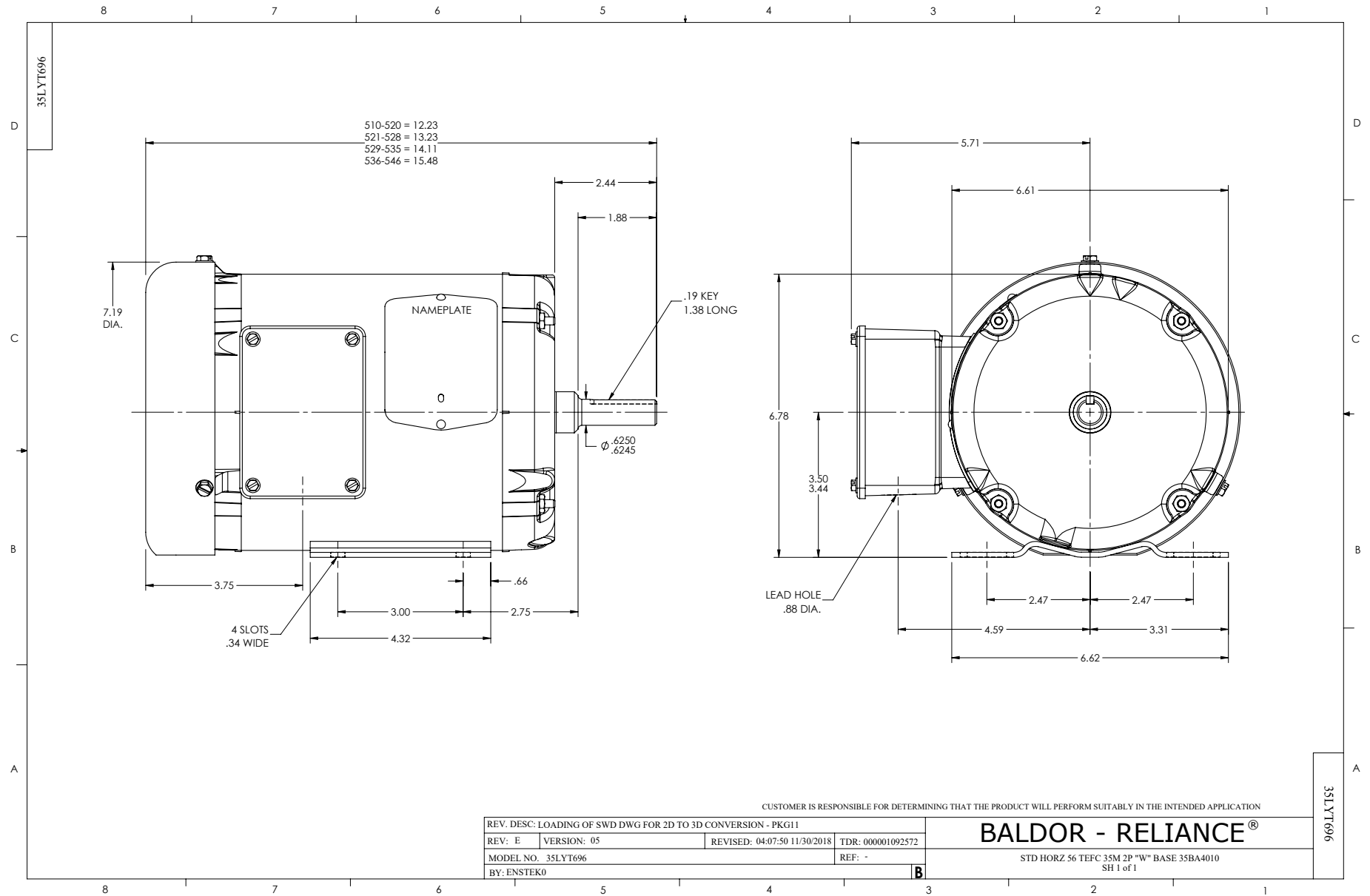

CD0006



NOTES:

1. THREE LEAD MOTOR MAY BE EITHER WYE CONNECTED OR DELTA CONNECTED.
2. INTERCHANGE ANY TWO LINE LEADS TO REVERSE ROTATION.
3. OPTIONAL THERMOSTATS ARE PROVIDED WHEN SPECIFIED.
4. ACTUAL NUMBER OF INTERNAL PARALLEL CIRCUITS MAY VARY.
5. LEAD COLORS ARE OPTIONAL. LEADS MUST BE NUMBERED AS SHOWN.

CD0006

REV. DESC: ADD CLASS CONN00000007		
REV. LTR: E	VERSION: 01	TDR: 000001099922
FILE: \AAA\00005\141	REVISED: 10:24:49 02/19/2019	BY: ENBRIRO
MTL: -	© □	

BALDOR - RELIANCE®

3PH, SV, 3 LEADS, WYE OR DELTA CONNECTED

SH 1 of 1