

**BALDOR • RELIANCE**

---

# Customer information packet

## EFM4100T

15HP, 1175RPM, 3PH, 60HZ, 284T, 1046M, TEFC, F2

Class - None

Division - Not Applicable

Copyright © All product information within this document is subject to ABB Motors and Mechanical Inc. copyright © protection, unless otherwise noted.

1/2/2023 12:12:16 PM

## Specifications

Enclosure	TEFC
Frame	284T
Frame Material	Iron
Frequency	60.00 Hz
Motor Letter Type	Three Phase
Output @ Frequency	15.000 HP @ 60 HZ
Phase	3
Synchronous Speed @ Frequency	1200 RPM @ 60 HZ
Voltage @ Frequency	460.0 V @ 60 HZ 230.0 V @ 60 HZ
XP Class and Group	None
XP Division	Not Applicable
Agency Approvals	CSA CSA EEV UR
Ambient Temperature	40 °C
Auxillary Box	No Auxillary Box
Auxillary Box Lead Termination	None
Base Indicator	Rigid
Bearing Grease Type	Polyrex EM (-20F +300F)
Blower	None
Current @ Voltage	42.000 A @ 208.0 V 42.000 A @ 230.0 V 21.000 A @ 460.0 V
Design Code	A
Drip Cover	No Drip Cover
Duty Rating	CONT
Efficiency @ 100% Load	91.7 %
Electrically Isolated Bearing	Not Electrically Isolated
Feedback Device	NO FEEDBACK
Front Face Code	Standard
Front Shaft Indicator	None

## Part detail

Revision	U
Type	AC
Mech. spec.	10C156
Base	
Status	PRD/A
Elec. spec.	10WGY561
Layout	10LYC156
Eff. date	07-12-2022
CD Diagram	CD0180
Poles	06
Leads	9#10
Proprietary	False
Created date	06-11-2014

Heater Indicator	No Heater
High Voltage Full Load Amps	21.0 a
Insulation Class	F
Inverter Code	Not Inverter
KVA Code	H
Lifting Lugs	Standard Lifting Lugs
Locked Bearing Indicator	Locked Bearing
Motor Lead Exit	Ko Box
Motor Lead Quantity/Wire Size	9 @ 10 AWG
Motor Lead Termination	Flying Leads
Motor Standards	NEMA
Motor Type	1046M
Mounting Arrangement	F2
Number of Poles	6
Overall Length	27.76 IN
Power Factor	73
Product Family	General Purpose
Pulley End Bearing Type	Ball
Pulley Face Code	Standard
Pulley Shaft Indicator	Standard
Rodent Screen	None
Service Factor	1.15
Shaft Diameter	1.875 IN
Shaft Extension Location	Pulley End
Shaft Ground Indicator	No Shaft Grounding
Shaft Rotation	Reversible
Shaft Slinger Indicator	Shaft Slinger
Speed	1175 rpm
Speed Code	Single Speed
Starting Method	Direct on line
Thermal Device - Bearing	NONE (OLD)
Thermal Device - Winding	None
Vibration Sensor Indicator	No Vibration Sensor
Winding Thermal 1	None

**Winding Thermal 2**

**None**

---

**Nameplate**

**NP3443LUA**

<b>CAT.NO.</b>	EFM4100T			<b>CUST. P/N</b>				<b>ENCL</b>	TEFC
<b>SPEC.</b>	10C156Y561G1	<b>CC</b>	010A	<b>FRAME</b>	284T		<b>SER.NO.</b>		
<b>HP</b>	15	<b>CLASS</b>	F	<b>HZ</b>	60				
<b>R.P.M.</b>	1175	<b>PH.</b>	3	<b>DES.</b>	A				
<b>VOLTS</b>	230/460	<b>CODE</b>	H	<b>ODE BRG</b>	6309	<b>DE BRG</b>	6311		
<b>AMPS</b>	42/21	<b>USABLE AT 208V</b>	42						
<b>RATING</b>	40C AMB-CONT	<b>NEMA NOM. EFF.</b>	91.7	<b>GREASE</b>	POLYREX EM				
<b>P.F.</b>	73	<b>SER.F.</b>	1.15	<b>CT6-60H(10:1)VT3-60H(20:1)</b>					
<b>USABLE AT</b>	50HZ 15HP 190/380V 48/24A			SF1.0					
<b>VOLTS</b>	<b>AMPS</b>	<b>MAX. SPACE HEATER TEMP.</b>							

**AC Induction Motor Performance Data**

Record # 29743

Typical performance - not guaranteed values

<b>Winding: 10WGY561-R001</b>		<b>Type: 1046M</b>		<b>Enclosure: TEFC</b>	
<b>Nameplate Data</b>			<b>460 V, 60 Hz: High Voltage Connection</b>		
<b>Rated Output (HP)</b>	15	<b>Full Load Torque</b>	66.5 LB-FT		
<b>Volts</b>	230/460	<b>Start Configuration</b>	direct on line		
<b>Full Load Amps</b>	42/21	<b>Breakdown Torque</b>	195 LB-FT		
<b>R.P.M.</b>	1175	<b>Pull-up Torque</b>	91.4 LB-FT		
<b>Hz</b>	60 <b>Phase</b>	3	<b>Locked-rotor Torque</b>	115 LB-FT	
<b>NEMA Design Code</b>	<b>A KVA Code</b>	H	<b>Starting Current</b>	125 A	
<b>Service Factor (S.F.)</b>	1.15		<b>No-load Current</b>	11.3 A	
<b>NEMA Nom. Eff.</b>	91.7	<b>Power Factor</b>	73	<b>Line-line Res. @ 25°C</b>	0.56099 Ω
<b>Rating - Duty</b>	40C AMB-CONT		<b>Temp. Rise @ Rated Load</b>	49°C	
<b>S.F. Amps</b>			<b>Temp. Rise @ S.F. Load</b>	59°C	
			<b>Locked-rotor Power Factor</b>	33	
			<b>Rotor inertia</b>	5.63 LB-FT <sup>2</sup>	

**Load Characteristics 460 V, 60 Hz, 15 HP**

<b>% of Rated Load</b>	<b>25</b>	<b>50</b>	<b>75</b>	<b>100</b>	<b>125</b>	<b>150</b>	<b>S.F.</b>
<b>Power Factor</b>	34	54	66	73	76	77	75
<b>Efficiency</b>	85	90.6	91.8	92	91.5	91.3	91.7
<b>Speed</b>	1197	1193	1188.7	1183.9	1179	1177.5	1181
<b>Line amperes</b>	12.2	14.3	17.3	20.8	25.1	26.1	23.4

ABB Motors and Mechanical Inc.

WINDING # 10WGY561

Typical performance - not guaranteed values.

15 HP 3 PH 60 HZ 1175 RPM 460 V 1046M

TORQUES (LB-FT): PO=195 PU=91.4 LR=115 LRA=125

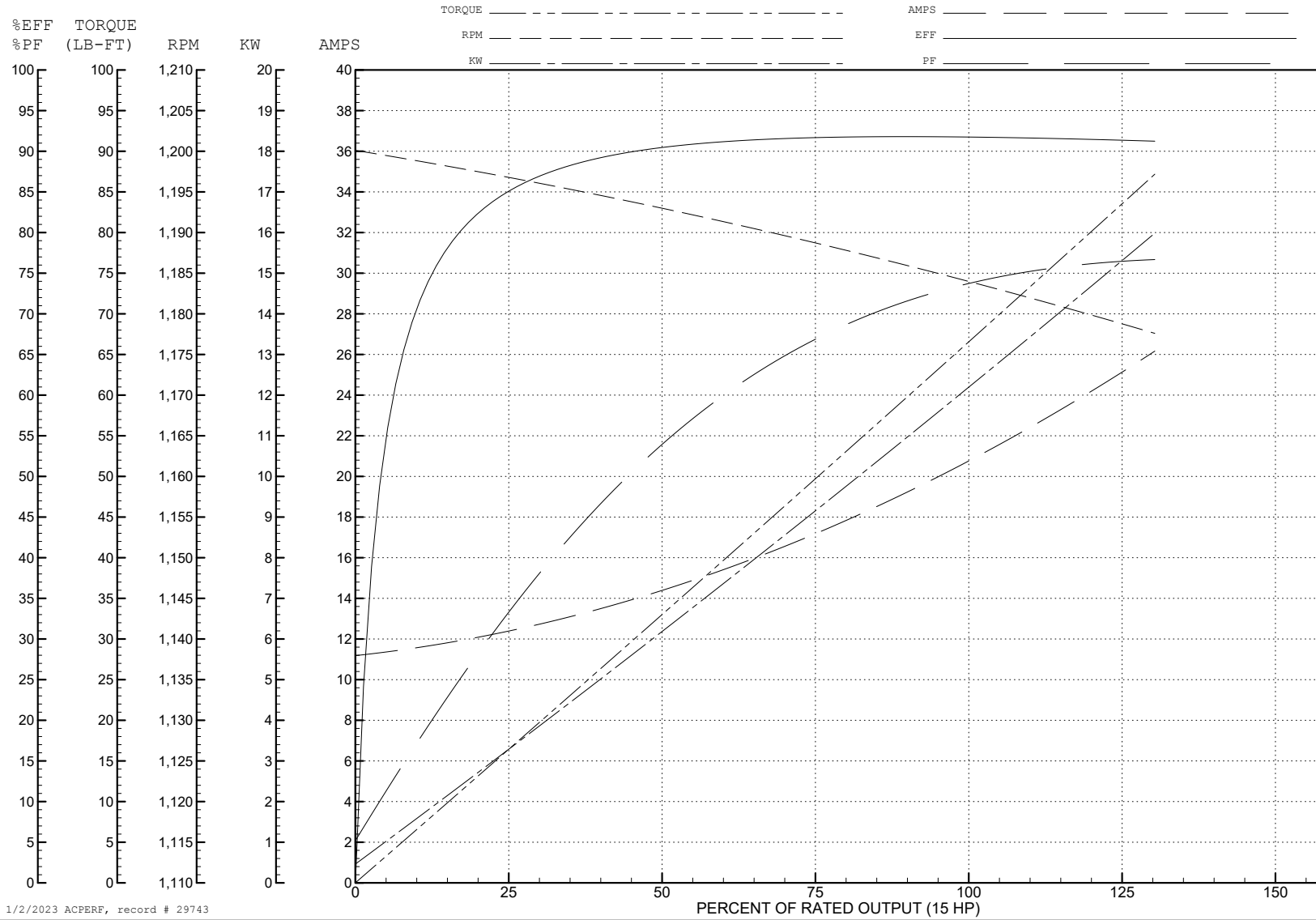

1/2/2023 ACPERF, record # 29743

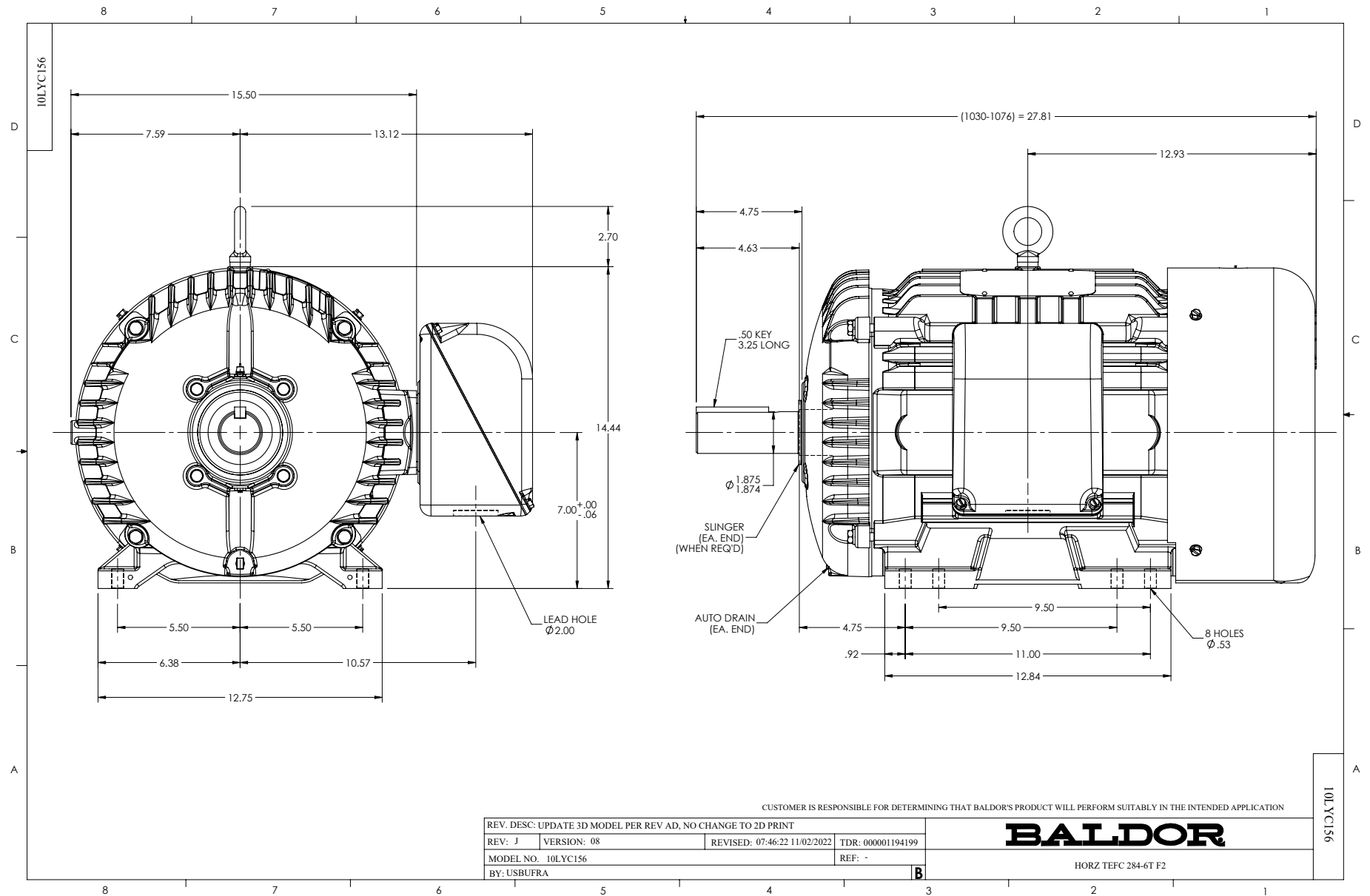



CD0180

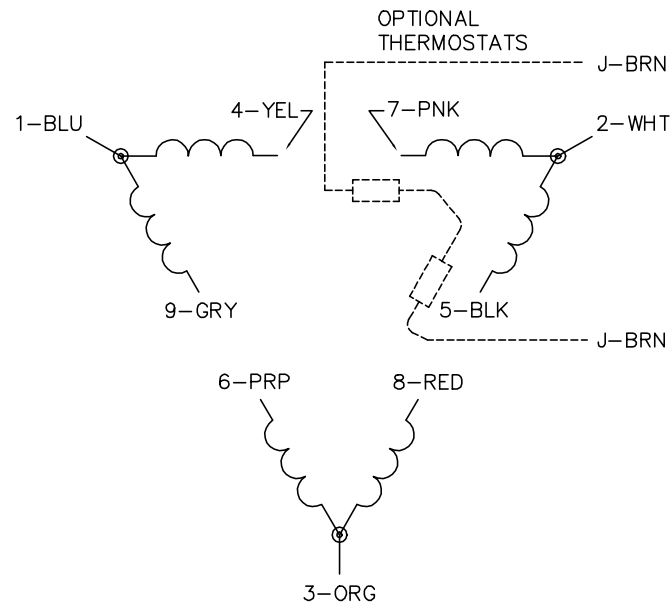

LOW VOLTAGE  
(2D)

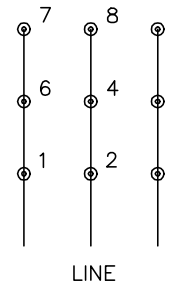

HIGH VOLTAGE  
(1D)

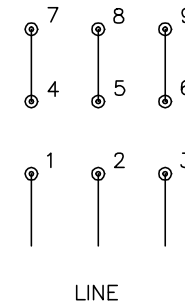

NOTES:

1. INTERCHANGE ANY TWO LINE LEADS TO REVERSE ROTATION.
2. OPTIONAL THERMOSTATS ARE PROVIDED WHEN SPECIFIED.
3. ACTUAL NUMBER OF INTERNAL PARALLEL CIRCUITS MAY BE A MULTIPLE OF THOSE SHOWN ABOVE.
4. LEAD COLORS ARE OPTIONAL. LEADS MUST ALWAYS BE NUMBERED AS SHOWN.

CD0180

REV. DESC: ADD CLASS CONN00000007		
REV. LTR: D	VERSION: 01	TDR: 000001099922
FILE: \AAA\00005\148	REVISED: 10: 25: 29 02/19/2019	BY: ENBRIRO
MTL: -	© □	

**BALDOR - RELIANCE®**

3PH, DV, 9 LEADS, DELTA CONNECTION

SH 1 of 1